

INSTALLATION MANUAL

- ⚠ Before starting installation, please take a few minutes to **READ THIS MANUAL CAREFULLY.**
- ⚠ Please check the product **CAREFULLY** for any visible damage.

Model/Modele : K1118

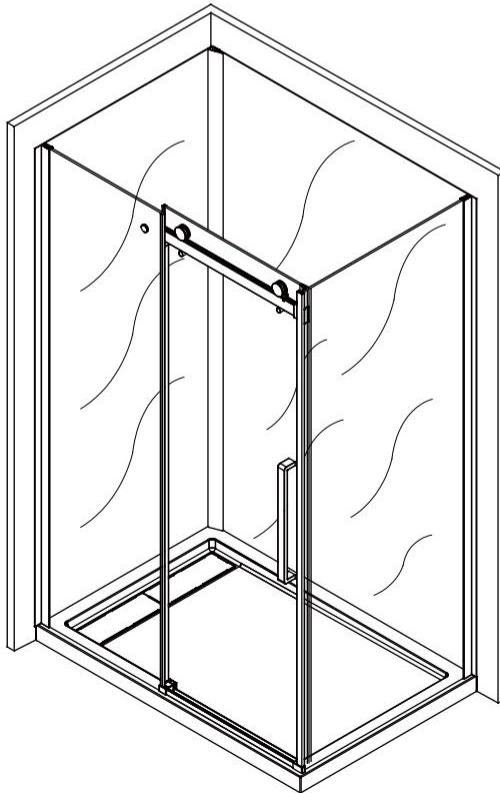

Introduction • Introduction

Thank you for your confidence in purchasing a DOLPHIN unit.

We can assure you that DOLPHIN uses only the finest materials and employs strict quality control measures to ensure that each and every unit meets the highest quality standards.

This manual contains general information on the installation of our units. It is important to closely follow the step-by-step instructions to closely follow the step-by-step instructions to ensure proper installation of your shower.

Merci d'avoir fait confiance à DOLPHIN pour l'achat de votre unité.

Nous pouvons vous garantir que DOLPHIN a utilisé les meilleurs matériaux et appliqué les mesures de contrôle de la qualité les plus rigoureuses pour s'assurer que chaque unité réponde aux normes les plus strictes.

Ce guide fournit des renseignements généraux concernant l'installation de nos unités. Il est important de bien suivre toutes les instructions pour assurer l'installation appropriée de l'unité.

Table of contents • Table des matières

A.Right to left opening B.Left to right opening

	A	B
Introduction	2	2
Table of contents	2	2
Before you begin	3	3
General considerations	4	4
Warning	4	4
Tools	5	5
Parts and components	6-8	6-8
Shower reversibility	9	9
Base installation	10	10
Preparation of shower area	11-12	11-12
Base installation	13-15	13-15
Wall Installation	16	16
Decorative column installation	17-23	36-41
Glass shelf installation	24	42
Shower door installation	25-35	43-53
Troubleshooting guide	54	54
Maintenance	54	54

A.Ouverture de la droite vers la gauche. B.Ouverture de la gauche vers la droite.

	A	B
Introduction	2	2
Table des matières	2	2
Avant de commencer	3	3
Règles générales	4	4
Mise en garde	4	4
Outils	5	5
Liste des pièces et composantes	6-8	6-8
Réversibilité de la porte de douche	9	9
Installation de la base	10	10
Préparation de la zone d'installation de la douche	11-12	11-12
Installation de la base	13-15	13-15
préparation des murs	16	16
Installation de la barre décorative	16-23	36-41
Installation des étagères	24	42
Installation des portes de la douche	25-35	43-53
Guide de dépannage	54	54
Entretien	54	54



Before you begin • Avant de commencer



Carefully read all instructions before beginning the installation. Consult local building codes to ensure that the installation complies with standards in your area.

Remove the unit from its packaging. Before disposing of the packaging material, inspect the unit carefully. Should you discover any damage or defect in the finish, contact your distributor. The warranty does not cover damages or defects in the finish after the unit has been installed. DOLPHIN is not responsible for any shipping damages once the product has been delivered to the carrier in good condition. Any complaint regarding damage occurring during transport must be made directly to the carrier.

Check to make sure you have received all shower components including all screws and hardware (see itemized Parts List on Page 5)

Move the unit close to where it is to be installed before beginning the work. If necessary, disassemble sections of the unit before moving it, retaining all nuts and bolts.

To protect the unit during installation, we recommend laying a piece of cardboard on the base.

If the unit is covered with a polyethylene protective film, do not remove it until the installation is complete to ensure maximum protection. Do remove the film, however, wherever two surfaces will be in permanent contact.

Ensure that the floor is level. If you are renovating, remove the existing drywall before doing the framing and plumbing. Make sure that the walls are properly insulated and comply with all applicable building codes.

The drain in your unit may be to the left, the middle or the right. Verify the drain location before drilling a hole in the floor.

If your unit includes factory-installed plumbing, consult the corresponding installation instructions and user guide for specific framing instructions.

Lire toutes les instructions attentivement avant de commencer l'installation. Consulter les codes de construction locaux pour assurer une installation conforme aux normes.

Retirer l'unité de son emballage. Avant de disposer de l'emballage, s'assurer que l'unité est en bon état. Si l'inspection révèle que l'unité est endommagée ou qu'il y a un défaut de finition, communiquer avec le distributeur. La garantie ne couvre pas les dommages ou les défauts de finition une fois l'unité installée. DOLPHIN cesse d'être responsable des dommages attribuables au transport dès que l'unité est acheminée au transporteur. Toute plainte liée à un dommage attribuable au transport doit être faite directement auprès du transporteur.

vérifiez si vous avez bien reçu toutes les composantes de la douche ainsi que toutes les vis et accessoires (consultez la liste des pièces à la Page 5).

Placer l'unité près du lieu d'installation avant de commencer les travaux. Démontez les sections de l'unité au besoin et conservez tous les boulons et écrous.

Afin de protéger l'unité lors de l'installation, il est conseillé de placer un morceau de carton dans le fond de l'unité.

Si une pellicule de plastique protège l'unité, ne l'enlever qu'après l'installation, mais dégager les endroits où deux surfaces seront jointes en permanence.

Vérifier si le plancher est de niveau. S'il s'agit de rénovations, on doit enlever les surfaces murales existantes avant d'installer la structure et la plomberie. Vérifier si les murs sont bien isolés et conformes au code du bâtiment en vigueur.

Certaines unités sont offertes avec le drain à gauche, à droite ou au centre : vérifier l'emplacement du drain avant de percer le plancher.

Si l'unité comporte un système de plomberie installé en usine, consulter le guide d'installation et d'utilisation correspondant pour connaître les renseignements spécifiques à la construction de la structure.



General considerations • Règles générales



Framing

DO NOT DO ANY FRAMING WORK UNTIL YOU HAVE RECEIVED THE UNIT. The framing structure must be measured against the unit to ensure a proper fit.

Plumbing

Install all plumbing and drainage before securing the unit in place. **It is always recommended to have the plumbing performed by a skilled professional plumber.**

Before drilling a hole in the floor for the drainpipe, ensure that the space beneath is free of pipes, floor joists, heating ducts and electrical wires.

Replacement parts

If you require replacement parts, do not return the unit to the store. Please contact customer service: www.dolphinhomeware.com

When ordering replacement parts, please specify the model number, item number and part description. To accurately identify parts, refer to the illustration in the parts and components section.

Construction de la structure

NE PAS CONSTRUIRE LA STRUCTURE AVANT D'AVOIR REÇU L'UNITÉ. Afin d'assurer une installation appropriée, on doit vérifier les dimensions de la structure à partir de celles de l'unité.

Plomberie

Mettre en place toute la plomberie et le tuyau d'évacuation avant de fixer l'unité. **Il est recommandé de faire exécuter ces travaux par un plombier professionnel et compétent.**

Avant de percer le plancher pour le tuyau d'évacuation, s'assurer qu'il n'y a aucun élément caché sous le plancher (tuyaux, solives, conduits de chauffage, fils électriques, etc.).

Pièces de rechange

Pour obtenir des pièces de rechange, ne pas renvoyer le produit au distributeur. Si c'était le cas avant l'installation, communiquez avec le service à la clientèle www.dolphinhomeware.com.

pour commander, il suffit de donner le numéro de modèle, le numéro de l'article et la description de la pièce. Se référer à l'illustration des pièces pour bien les identifier.



Warning • Mise en garde



BE VERY CAREFUL WHEN HANDLING THE TEMPERED GLASS PANELS. To protect them after unpacking, place the panels in an upright position on a piece of cardboard or cloth in a safe location.

To prevent breakage, avoid knocking the panels together or against any other surface.

We strongly recommend wearing gloves when handling glass panels.

Shower assembly involves the use of tapping screws. Proper lubrication is essential for ease of assembly.

Tighten screws by hand - do not use an electric drill.

Note: The base must be installed directly against studs (not a finished wall).

PORTER UNE ATTENTION PARTICULIÈRE À LA MANIPULATION DES PANNEAUX DE VERRE TREMPÉ. Une fois les panneaux déballés, les déposer à la verticale sur un morceau de carton ou de tissu et les placer en lieu sûr pour éviter de les endommager.

Éviter de les entrechoquer et de les cogner contre d'autres surfaces. Des bris importants pourraient en résulter.

Il est fortement suggéré de porter des gants lors de la manipulation des panneaux de verre.

Le montage de la douche exige l'utilisation de vis taraudeuses. Une bonne lubrification est nécessaire afin de faciliter le montage.

Serrez les vis à la main. N'utilisez pas de perceuse électrique à cette fin.

Note : La base doit être installée directement contre les montants (pas sur le mur fini).

Tools • Outils



Level



Tape Measure



Pencil



Phillips Screwdriver



Silicone



Power Drill



**Drill Bit
Ø1/8"
(3mm)**



**Drill Bit
Ø1/4"
(6mm)**



Soft Head Hammer



Professional-grade Glass suction cup

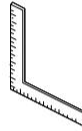

Square



Soft Cloth or Blanket



Safety Glasses



Work Gloves



Hacksaw



Razor Knife

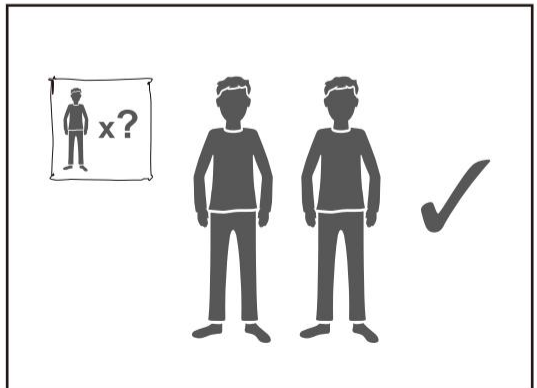

Parts and components • Liste des pièces et composantes

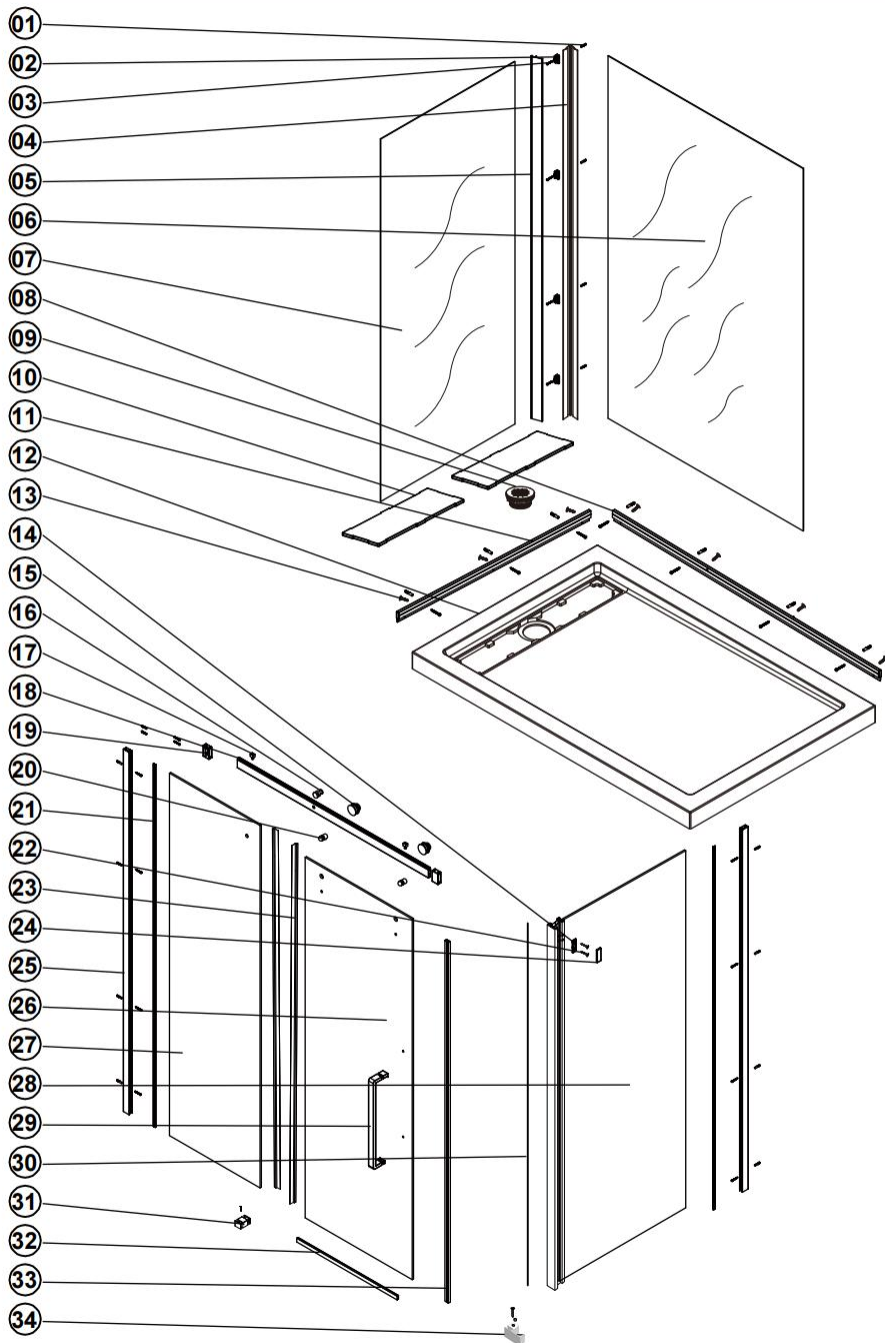

Parts and components • Liste des pièces et composantes

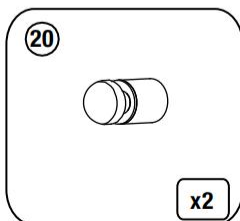
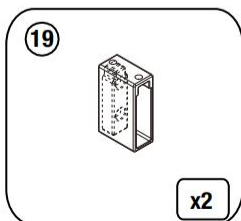
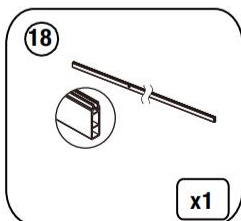
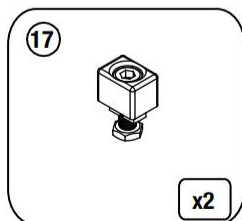
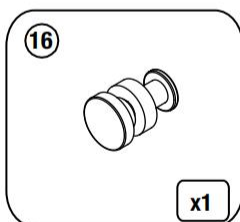
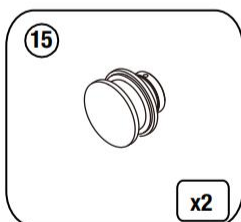
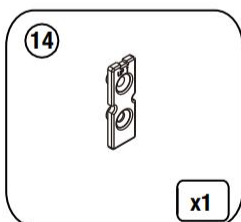
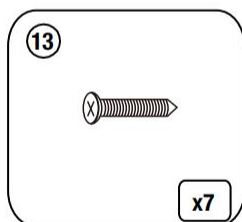
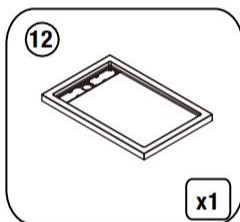
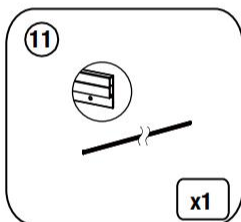
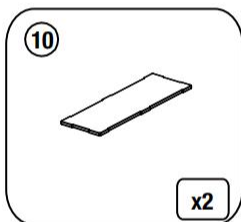
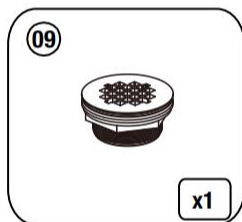
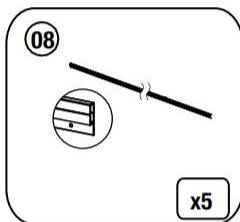
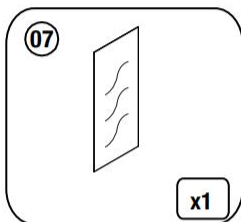
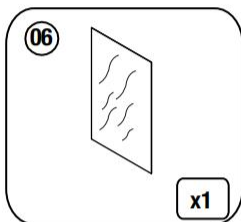
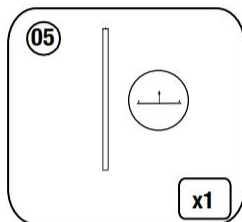
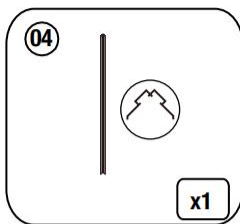
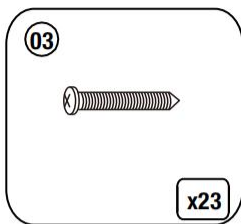
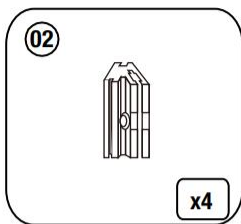
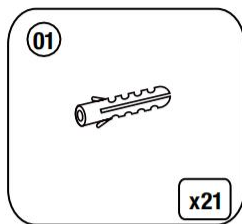

Parts and components • Liste des pièces et composantes

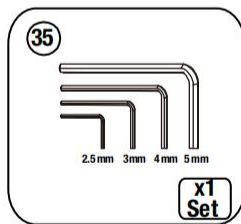
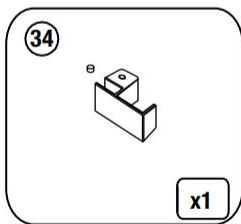
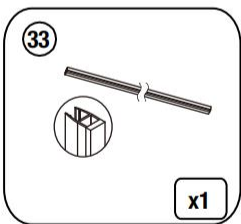
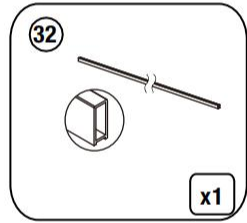
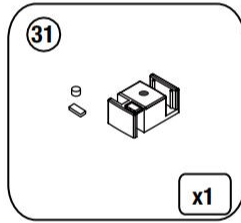
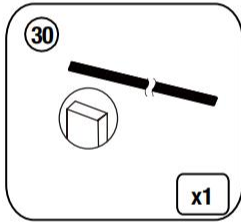
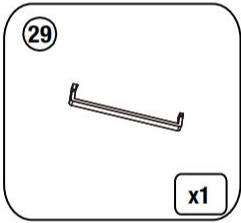
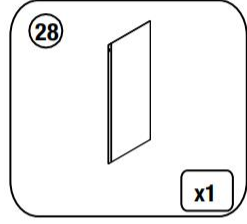
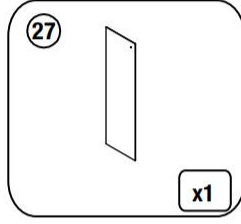
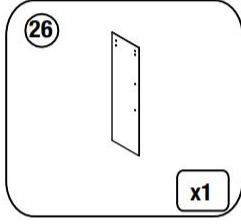
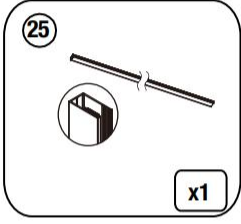
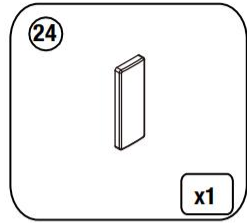
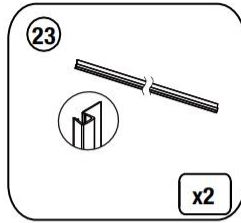
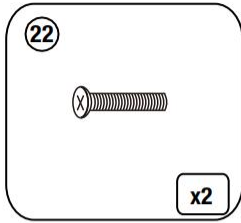
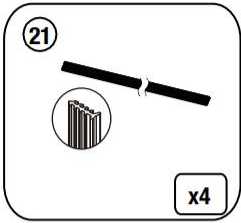

Shower reversibility • Réversibilité de la porte de douche

Verify the threshold and walls with a level.

If the walls are uneven, the products can accommodate up to 3/5" door side for out-of-plumb installation.

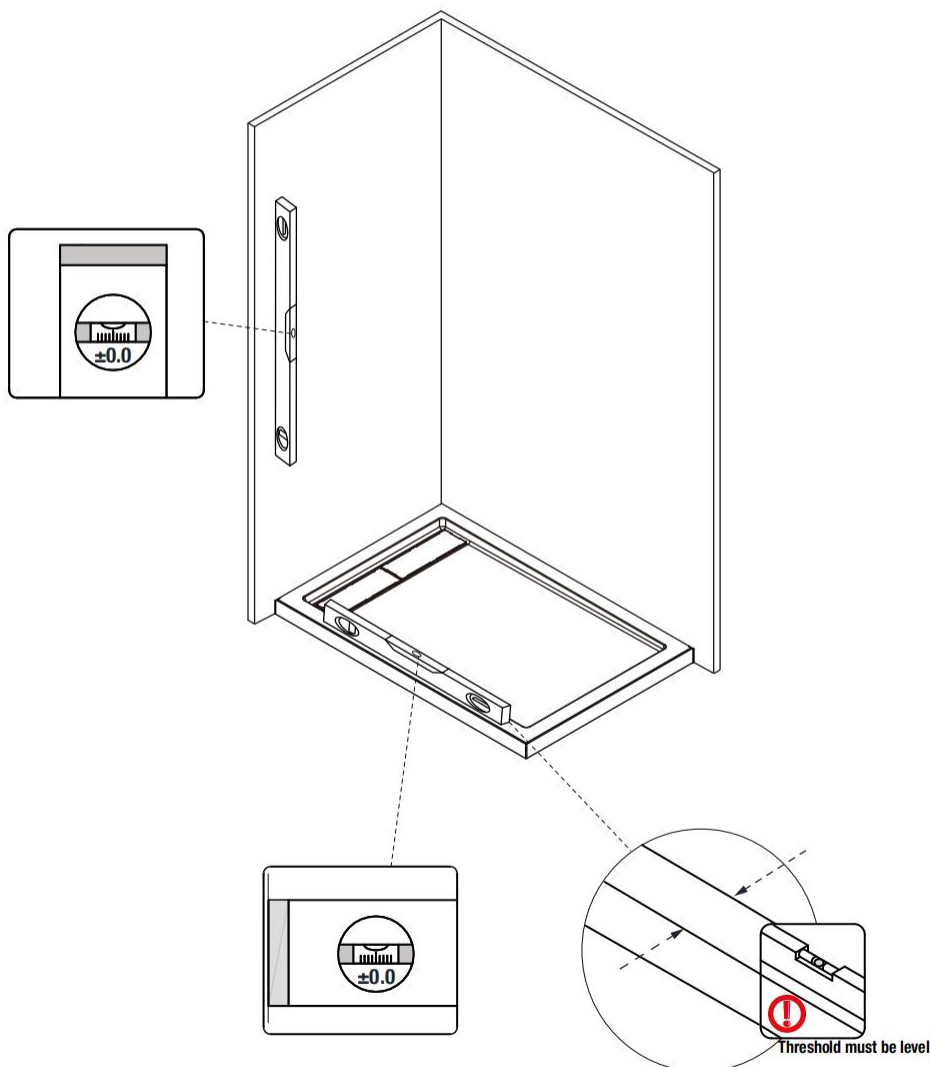

Base installation • Installation de la base

Install the tiling flange (08&11) on the base as shown in illustration.

Installez la bride de carrelage (08&11) sur la base comme indiqué sur l'illustration.

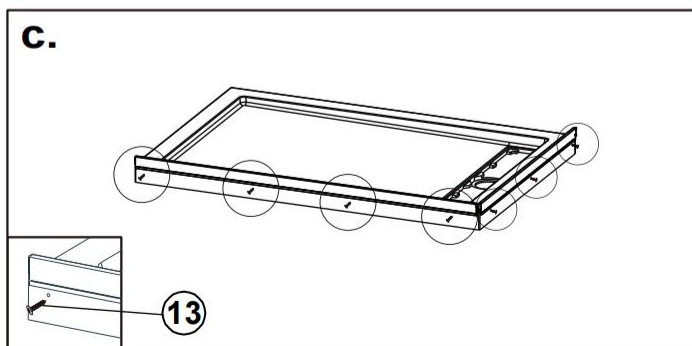
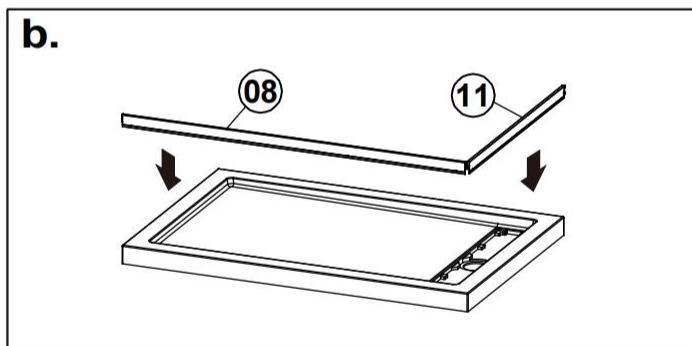
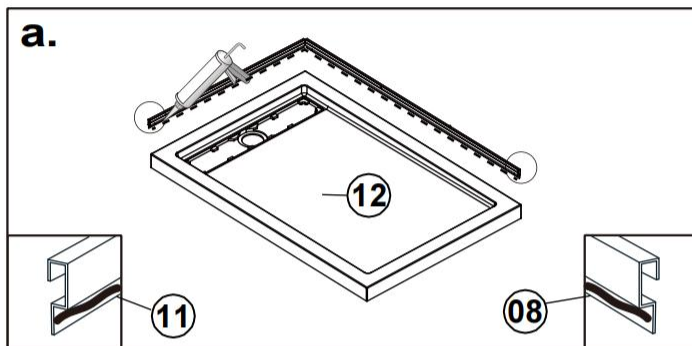

Preparation of shower area Préparation de la zone d'installation de la douche

For new construction, and wherever possible for renovation, install an extra stud in each wall centered on 30" and 46" (761mm & 1168mm) from the stud wall corner.

Pour les nouvelles constructions, et chaque fois que possible pour la rénovation, installer un clou supplémentaire dans chaque paroi centrée sur 30" et 46" (761mm et 1168) à partir du coin de mur.

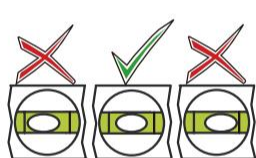
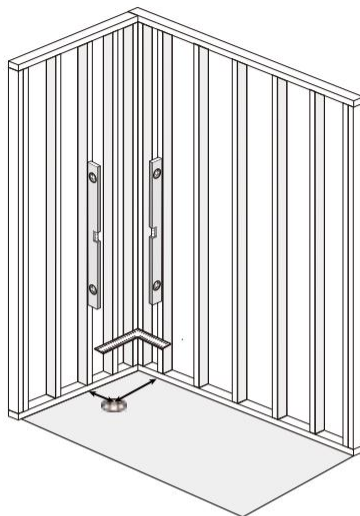



Leveling the floor is critical for wall alignment
Mise à niveau du sol essentielle pour l'alignement du mur.

Quick tip
Astuces rapides



For leveling the floor use self-leveling mortar.
pour niveler le sol, utiliser un mortier auto-niveleur.

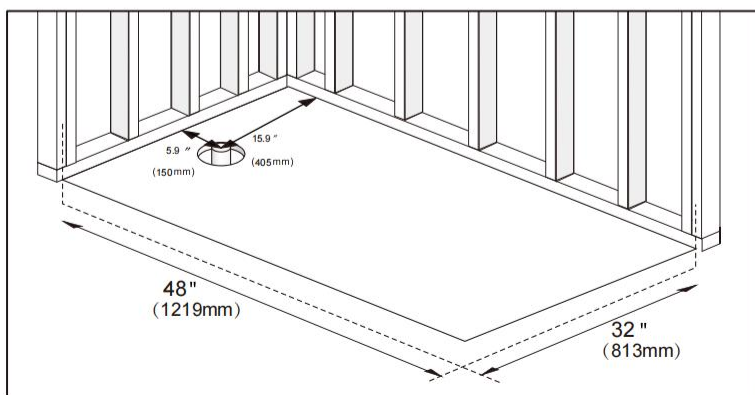
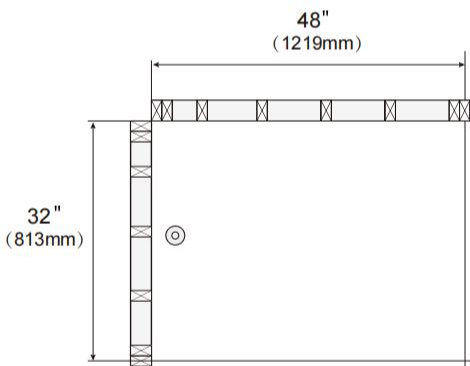

Preparation of shower area Préparation de la zone d'installation de la douche

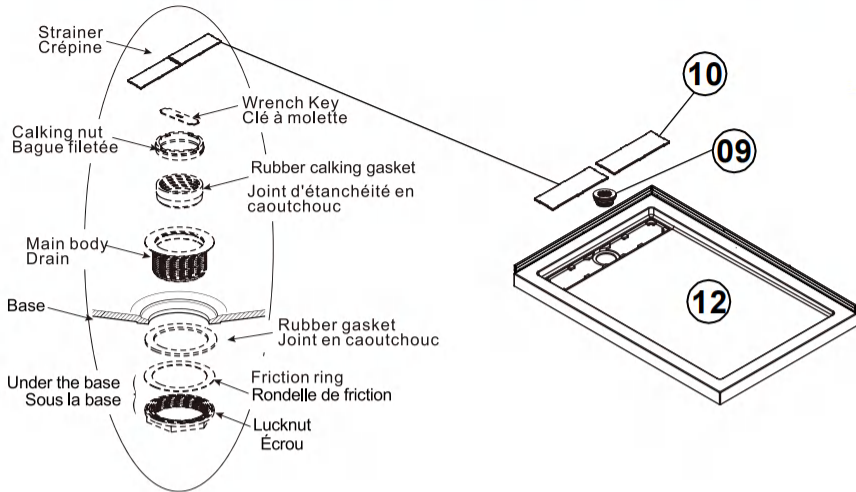

To compensate for any irregularities in your floor, the base must be shimmed properly from underneath to provide a level threshold for mounting purposes. Any shims must support the entire base: not only at one point. Verify this by standing on the base, once shimmed, and check for any spring or bounce in the base.

Particularly near drain area. Before final installation (wedge retainer insertion) make sure the base is level and that water drains away properly without "pooling" at any location. Use tape around drain to seal temporarily and pour 1-2 cups of water around extremities of the tray to test drainage.

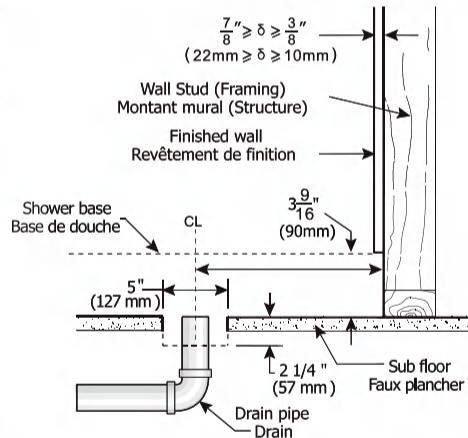

Pour compenser toutes les irrégularités dans votre plancher, la base doit être installé proprement en dessous pour fournir un seuil de niveau à des fins de montage. Toutes les cales doivent supporter la base, non seulement à un moment donné. Vérifiez ceci en se tenant bedout sur la base, une fois calé, et vérifier tout ressort ou un rebond dans la base, plus particulièrement près de la zone du drain. Avant installation finale (insertion du coin de retenue assurez-vous que la base est de niveau et que l'eau s'écoule correctement. Utiliser un ruban adhésif autour du drain pour sceller temporairement et versez 1-2 tasses d'eau autour des extrémités afin de tester le drainage.

Base installation • Installation de la base

Pave the cement at the position where you want to install the base.

Pavé le ciment à l'endroit où vous voulez installer la base.

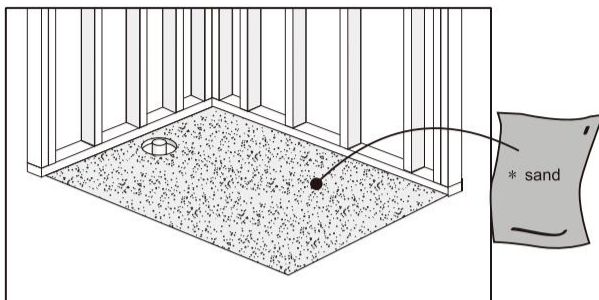

Put down the base on the cement.

Posez la base sur le ciment.

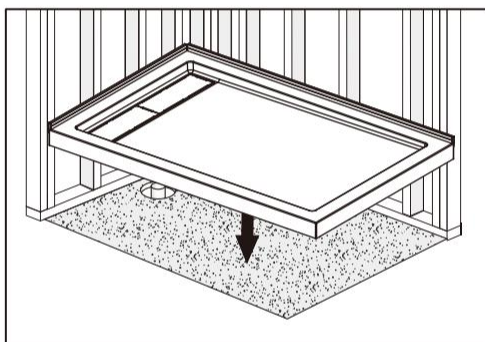

Drill through the tiling flange to fix the base on the wall with screw (01&03)

Percez à travers la bride de carrelage pour fixer la base sur le mur avec la vis (01&03)

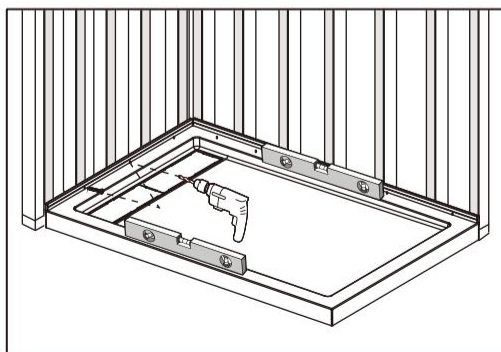
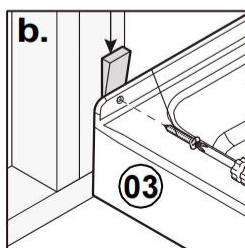
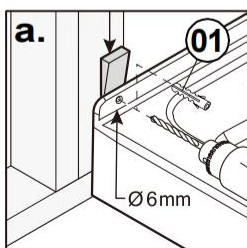

Base installation • Installation de la base

Apply the silicone to the tiling flange as shown in the illustration.

Appliquez le silicone sur la bride de carrelage comme indiqué sur l'illustration.

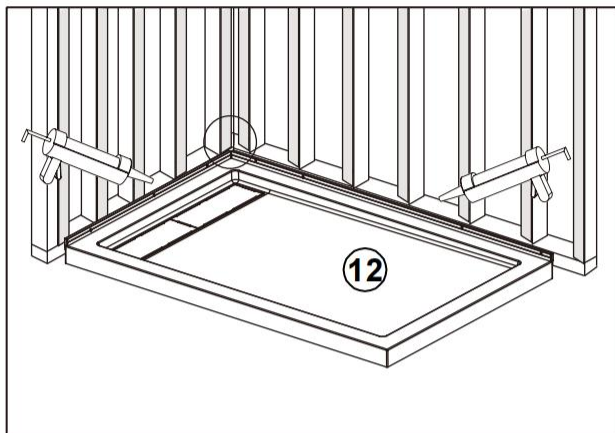
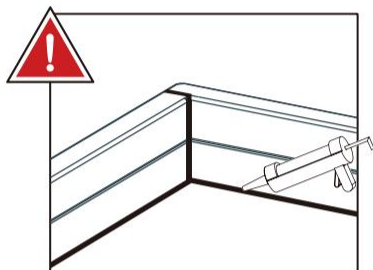

Note

the base is installed against the studs, not the finished walls. If necessary, remove finished wall to expose studs.

Remarque

la base est installée contre les poteaux, pas les murs. Si nécessaire, retirer le mur de finition pour voir les clous.

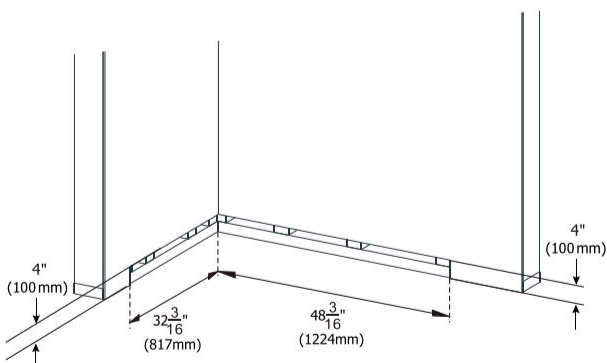

Base installation • Installation de la base

Note

The wall panels should be installed at a temperature near 16°C(60°F) and must not be installed in unheated areas where temperatures might drop below 0°C(32°F).

The wall panels can be installed over drywall, plaster, painted walls, plywood or ceramic tile, Wall surfaces must be solid, dry, clean and smooth. Scrape off any loose paint, wallpaper or plaster. It is strongly recommended that raw plaster or new wallboard be primed or water sealed prior to installation.

If the panels are being installed over existing tile, and over 30% of the removed during wall preparation, it is recommended that the remaining tiles also be removed. Existing ceramic tile should be lightly sanded. The vertical alignment from the edge of the shower base each side, and draw plumb lines on.

Remarque

Les panneaux muraux doivent être installés à une température proche de 16 ° C (60 ° F) et ne doivent pas être installés dans des endroits non chauffés où les températures peuvent descendre en dessous de 0 ° C (32 ° F).

Les panneaux muraux peuvent être installés sur les cloisons sèches, le plâtre, les murs peints, de contreplaqué ou de carreaux de céramique, surfaces muraux doivent être solides, secs, propres. Gratter la peinture écaillée, papier peint ou autre. Il est fortement recommandé que le plâtre brut ou nouveau mur soit amorcé ou l'eau fermé avant l'installation.

Si les panneaux sont installés sur des carreaux existents, il est recommandé que les tuiles restantes soient enlevées. Les carreaux de céramique existentes doivent être légèrement sablées.

L'alignement vertical du bord de la base de douche de chaque côté, et tracer des lignes avec un crayon de plomb

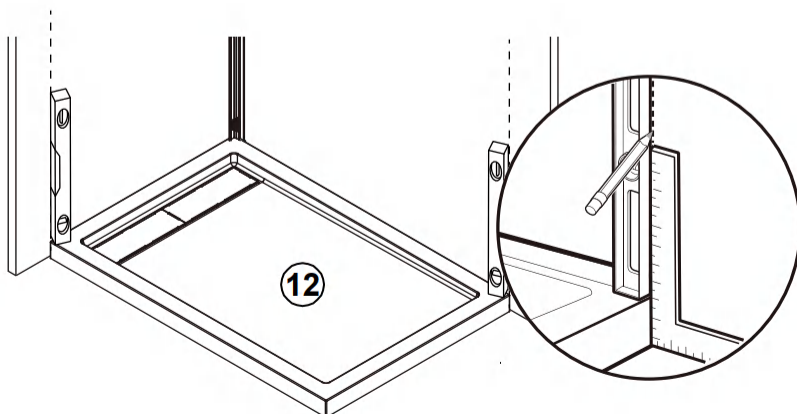

Wall Installation • préparation des murs

Measuring from the shower base and the plumb line on the wall, determine the locations of plumbing fixtures. Cut or drill fixture holes in the wall panel. If a knife is used, be certain that it is well sharpened. Do not try to cut through the plastic all at once; score it over and over, cutting a little deeper each time until you reach the other side. After having drilled the holes, lay the panel against the wall and check to see if the holes have been drilled in the right locations.

Mesure de la base de douche et le fil à plomb sur le mur, déterminer les emplacements des appareils de plomberie. Couper ou percer des trous dans le panneau mural. Si un couteau est utilisé, être certain qu'il est bien aiguisé. Ne pas essayer de couper à travers le plastique tout à la fois; couper un peu plus à chaque fois jusqu'à ce que vous atteignez l'autre côté. Après avoir percé les trous, poser le panneau contre le mur et vérifier pour voir si les trous ont été forés dans les bons endroits.

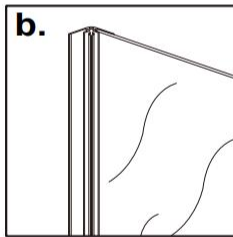
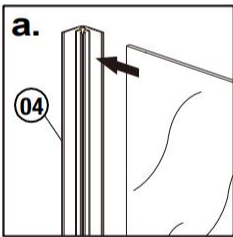
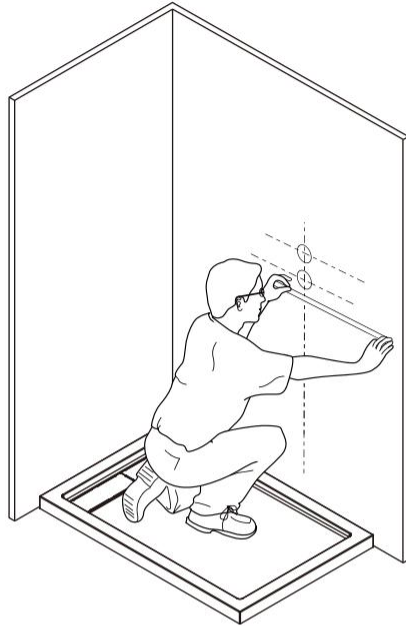

Holes saws can be purchased at your local hardware store or any tool rental location

Une scie à trous peut être achetée dans une quincaillerie ou magasin à outils.

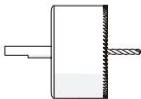

For safe hole saw usage always pre-drill a hole and wear safety glasses when drilling.

Pour percer un trou en toute sécurité, toujours pré-percer un trou et porter des lunettes de sécurité lors du perçage.

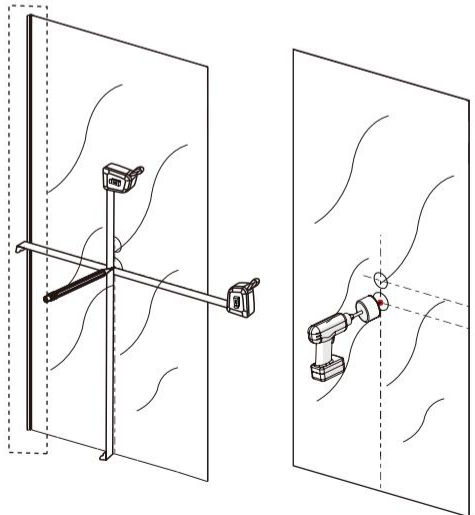

Decorative column installation • Installation de la barre décorative

NOTE

This model is reversible for right or left-hand door installation. For right-hand door installation, please refer to P18-P35, for left-hand door installation, please refer to P36-P53.

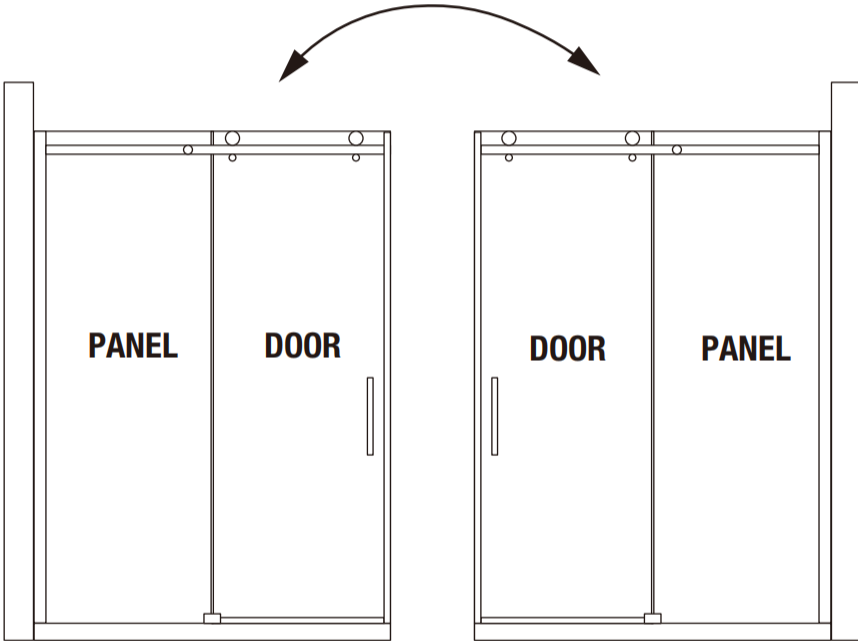

CAUTION!



**TWO PERSON
LIFT REQUIRED**



Decorative column installation • Installation de la barre décorative

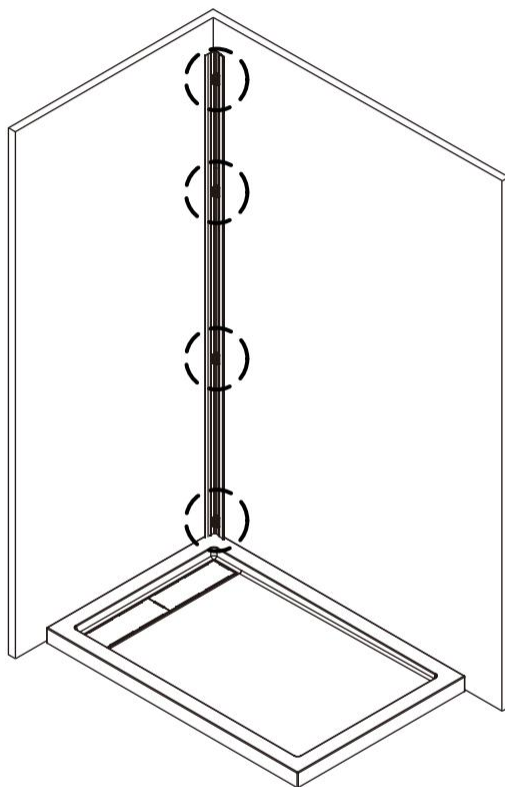
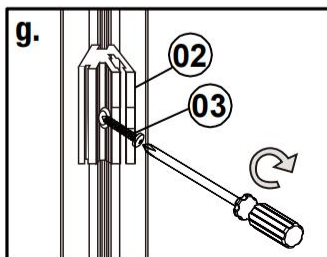
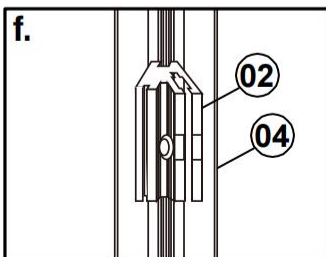
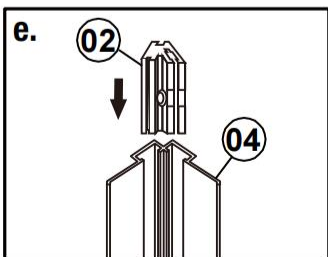
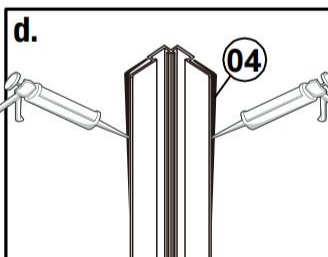
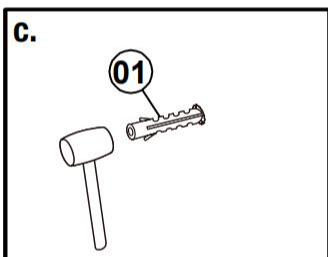
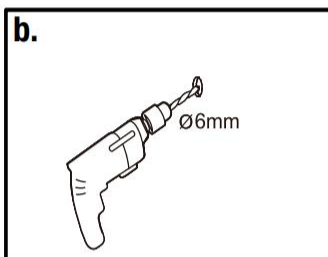
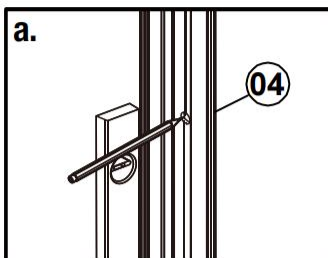

Decorative column installation • Installation de la barre décorative

Note:
Allow 24 hours for silicone to dry.

Remarque:
Laisser sécher le silicone pendant 24 heures.

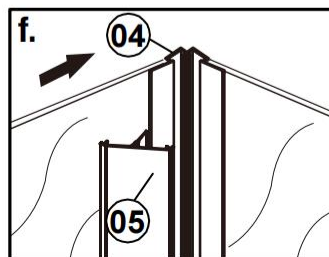
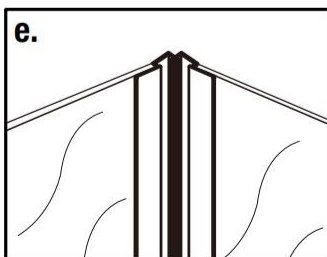
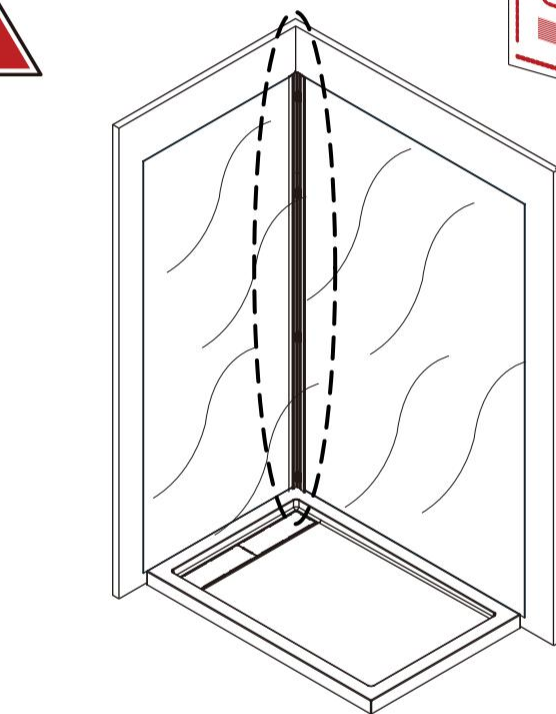
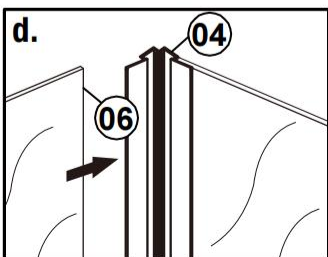
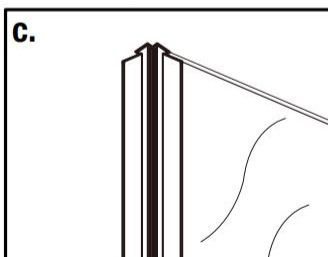
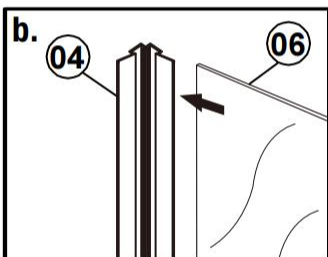
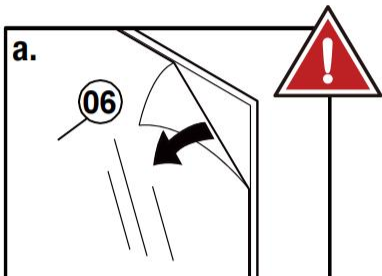
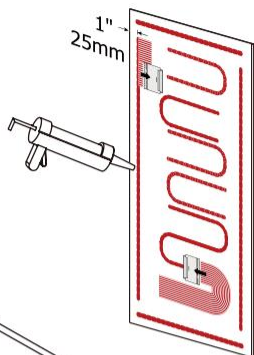

Decorative column installation • Installation de la barre décorative

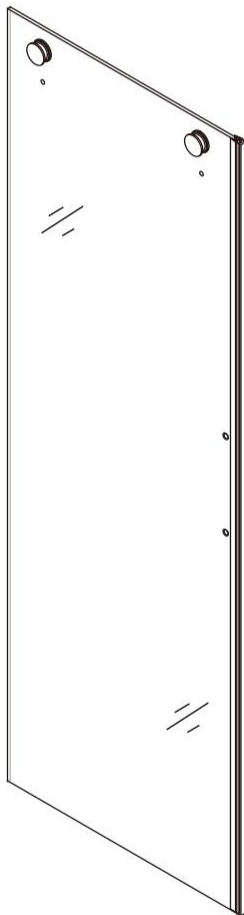
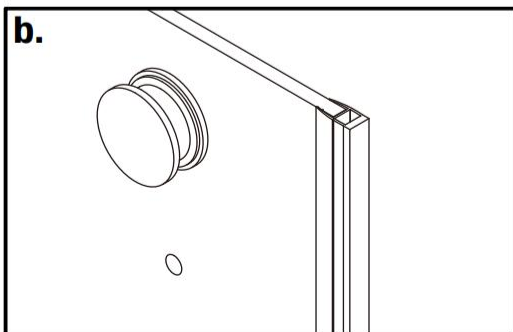
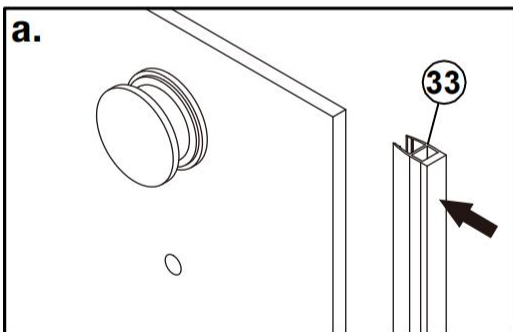
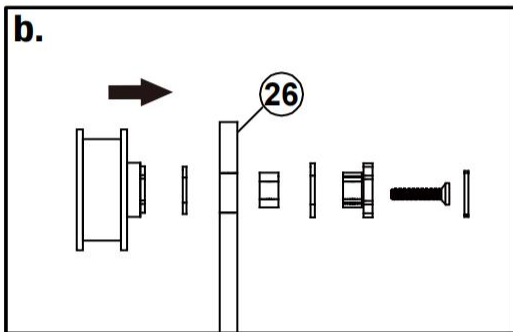
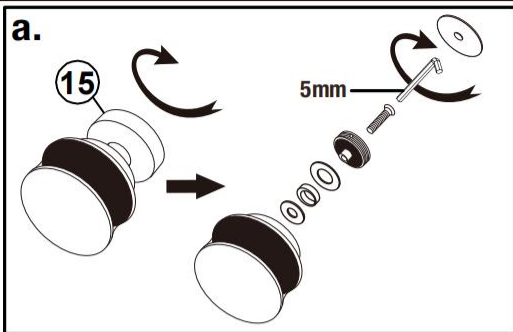

Decorative column installation • Installation de la barre décorative

Cover the shower base with a soft cloth/blanket. Carefully handle the glass door(15) to avoid scratching the shower base.

Attention:

DO NOT attach the handle to the Door Glass until instructed.

DO NOT attempt to lift the Glass Door with the handle as this may result in damage to the glass and/or serious personal injury. Use a professional grade glass suction cup and an assistant.

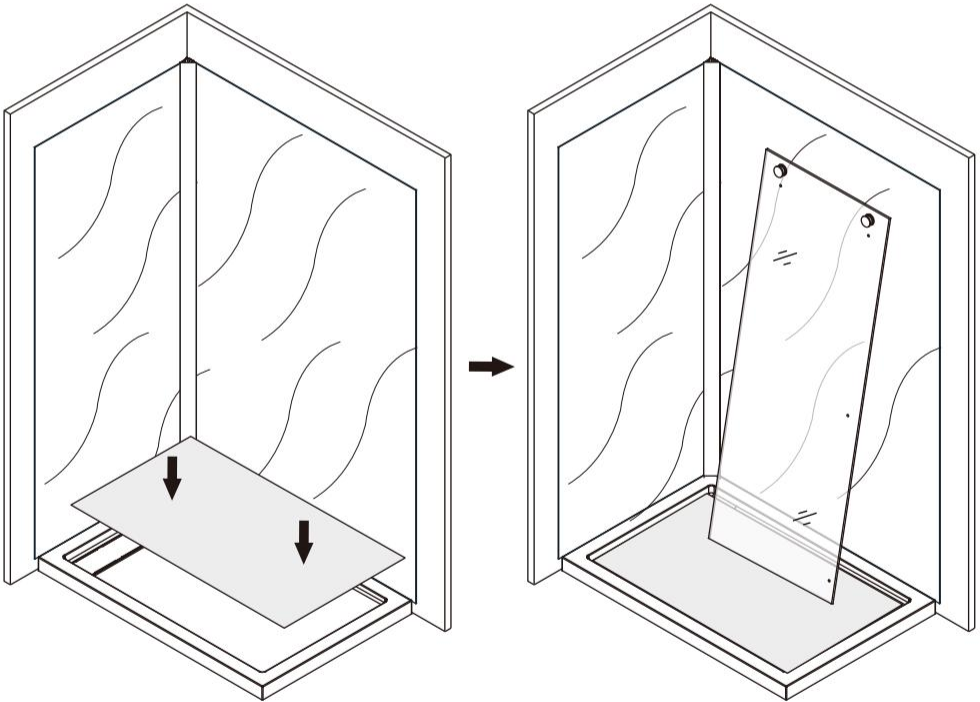

Decorative column installation • Installation de la barre décorative

Place the Wall Jamb on the OTHER side, mark down the predrilled position of the Wall Jamb. Drill the hole with 6mm drill bit, put silicone to the hole and then put anchor into the hole. Secure the Wall Jamb with M4*30 Screws.

Right-hand door installation shown. Continue on the right side for left-hand door installation.

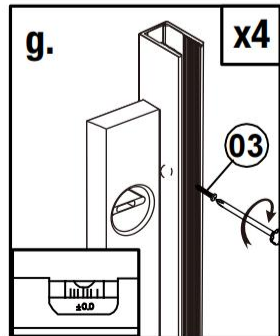
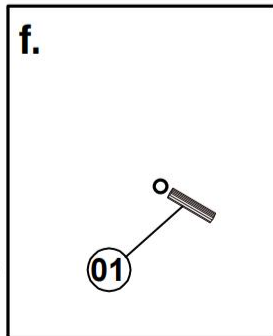
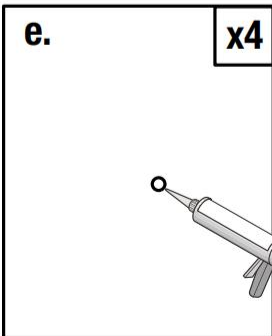
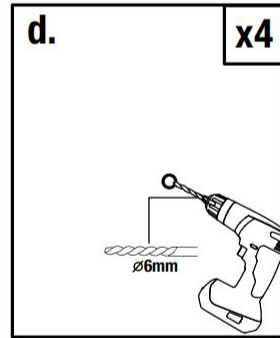
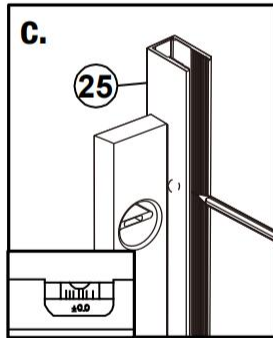
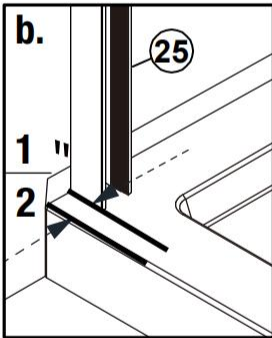
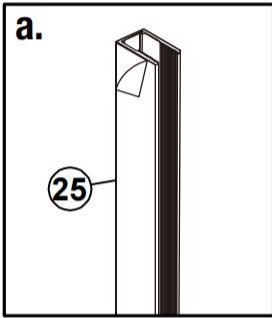
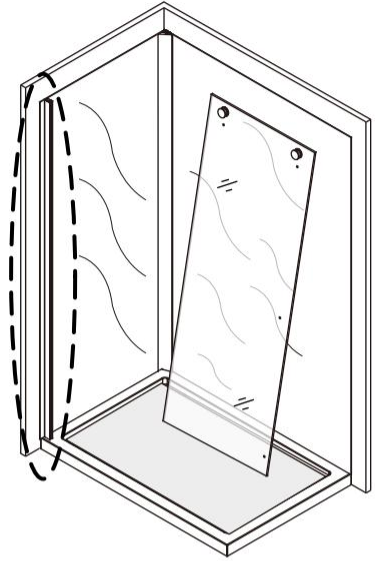

Decorative column installation • Installation de la barre décorative

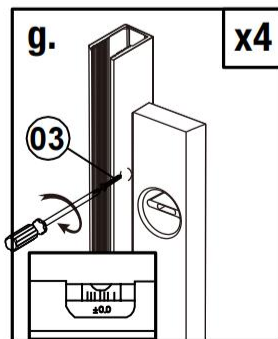
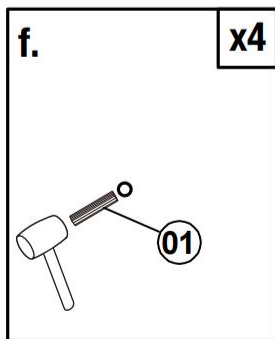
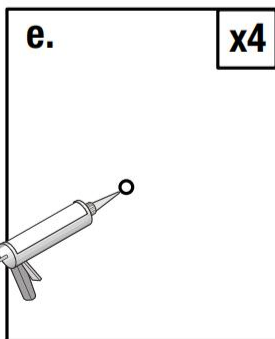
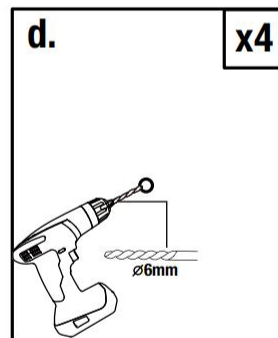
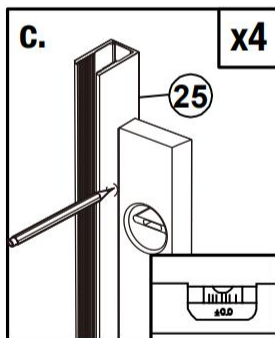
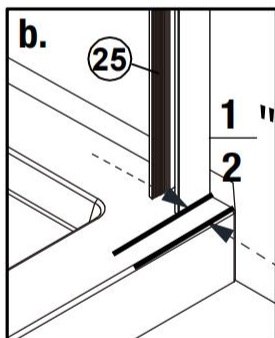
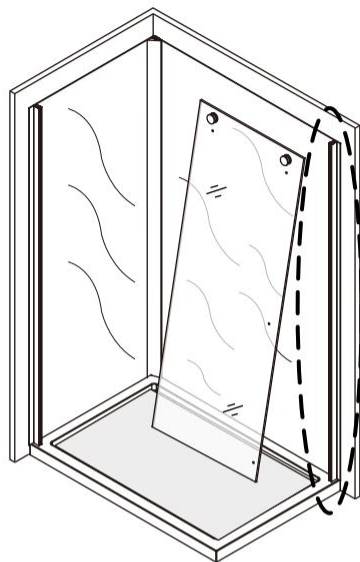
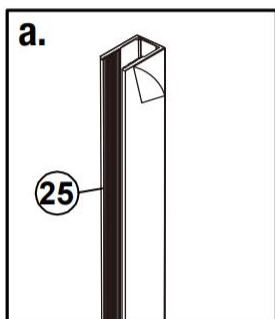

Glass shelf installation • Installation des étagères

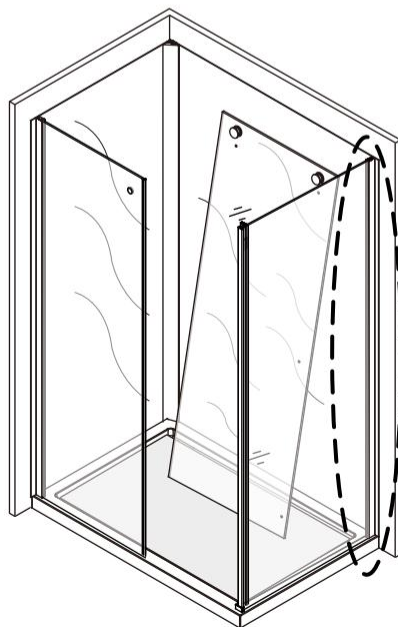
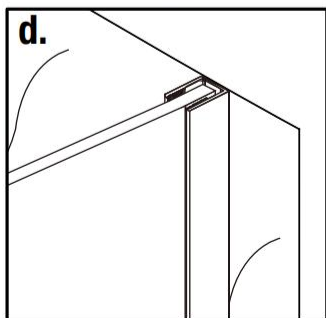
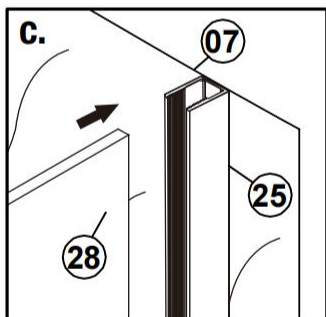
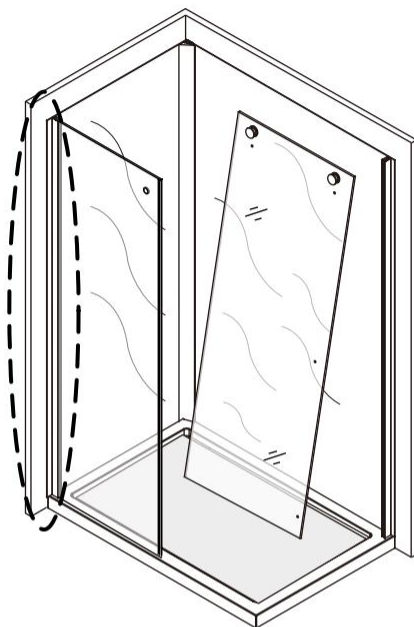
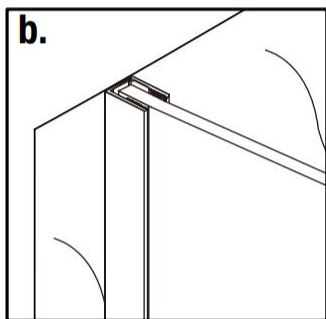
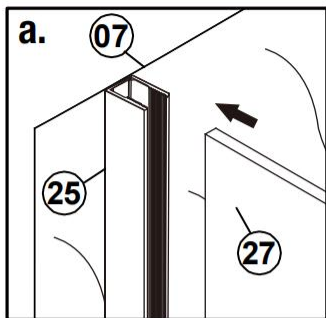

Shower door Installation • Installation des portes de la douche

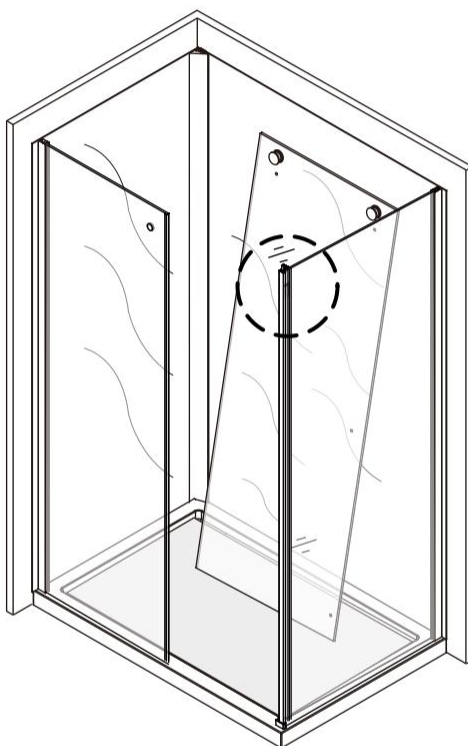
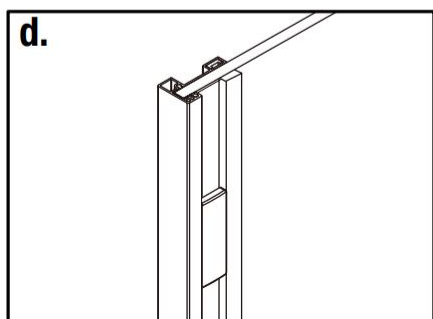
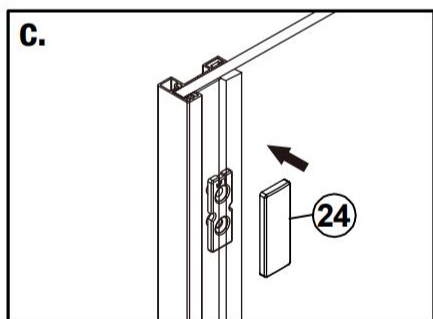
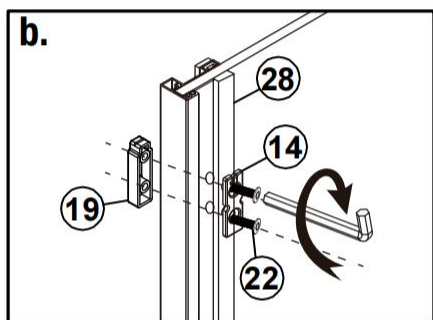
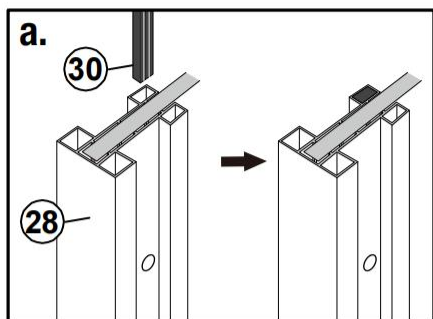

Shower door Installation • Installation des portes de la douche

Use the allen key (4mm) to loose the screw on the Guide Rail Brackets. Slide the Guide Rail Bracket onto the Guide Rail and use the allen key to temporarily tighten (slightly) the part to the Guide Rail.

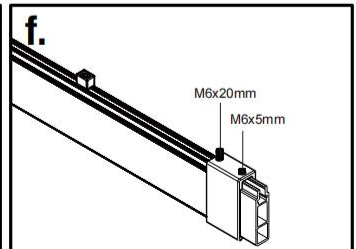
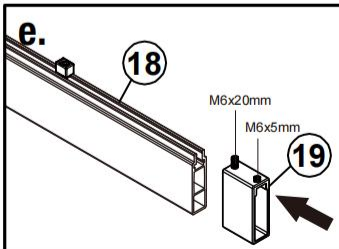
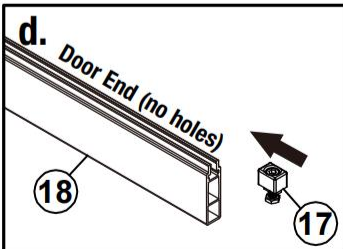
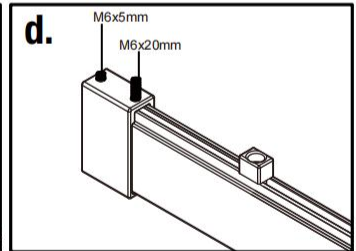
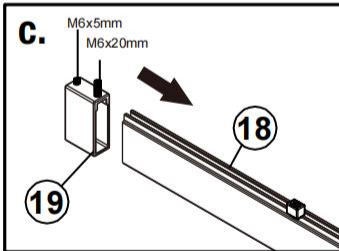
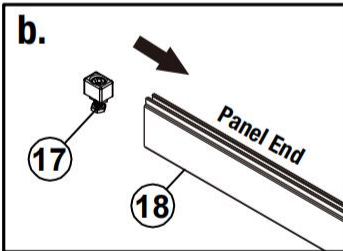
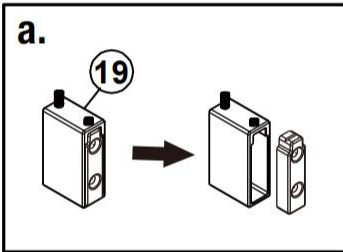
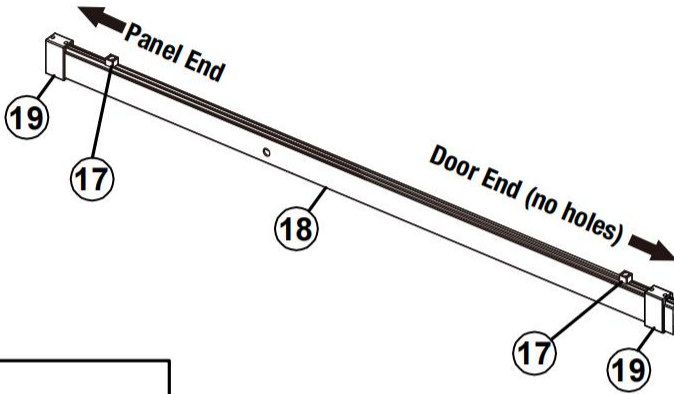

Shower door Installation • Installation des portes de la douche

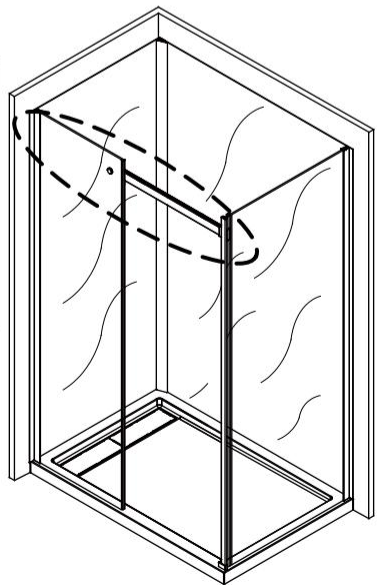
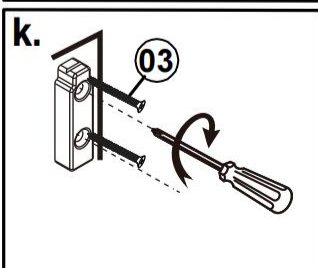
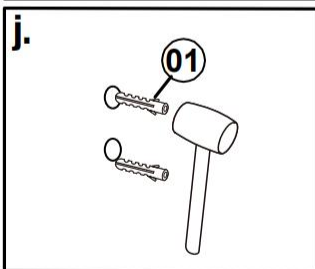
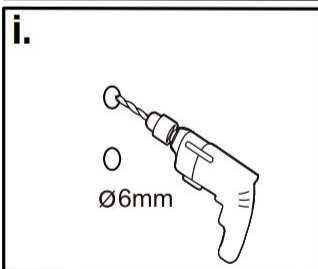
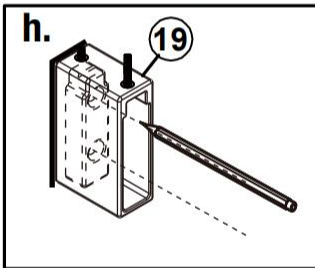
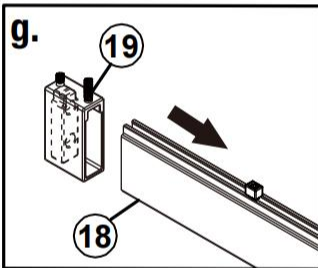
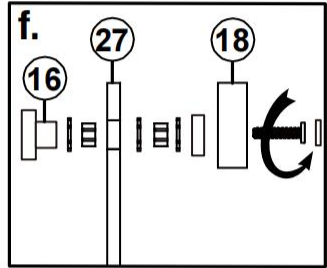
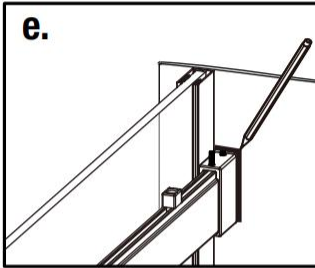
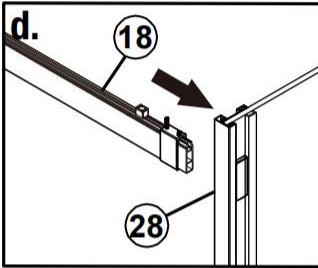
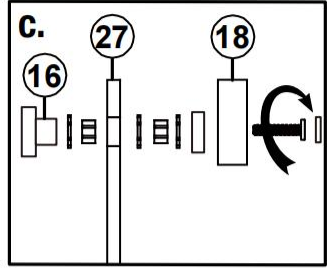
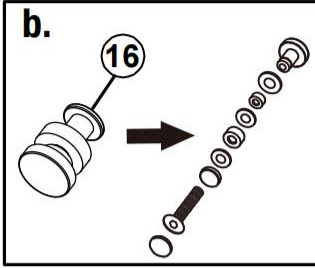
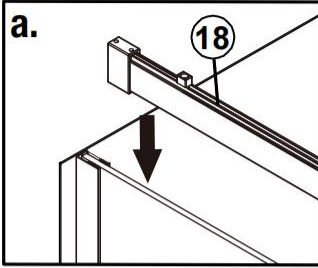

Shower door Installation • Installation des portes de la douche

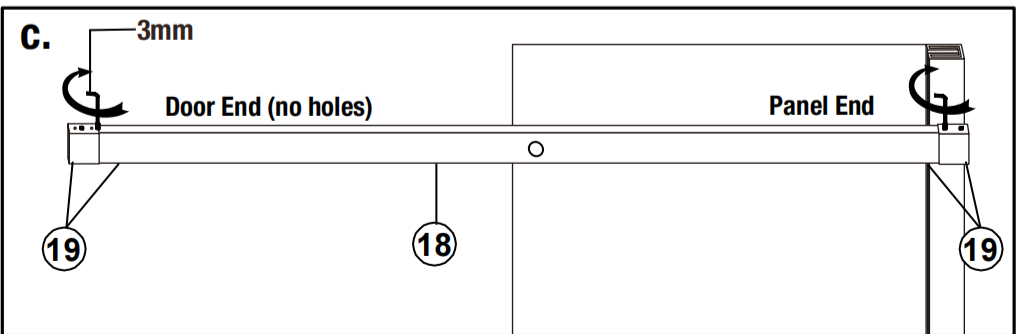
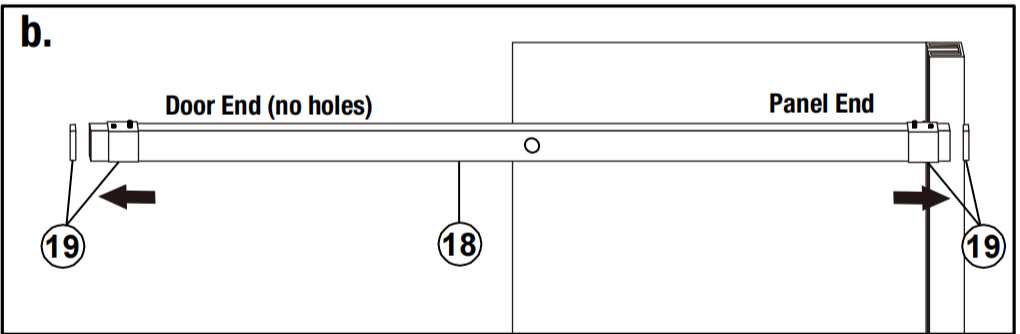
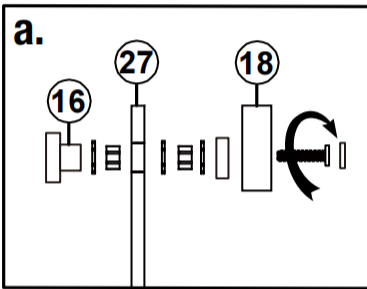
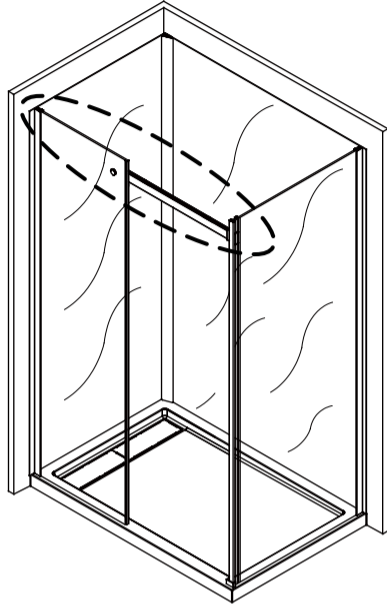

Shower door Installation • Installation des portes de la douche

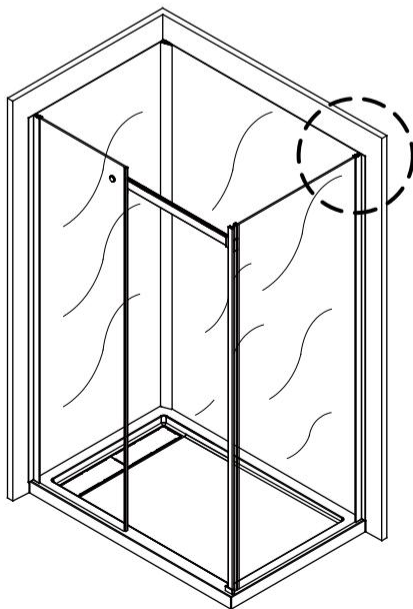
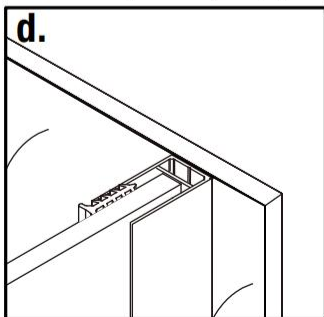
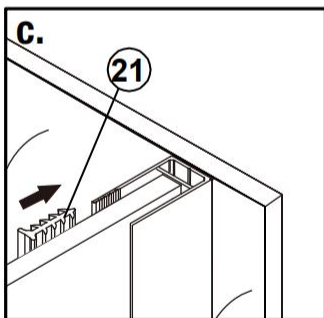
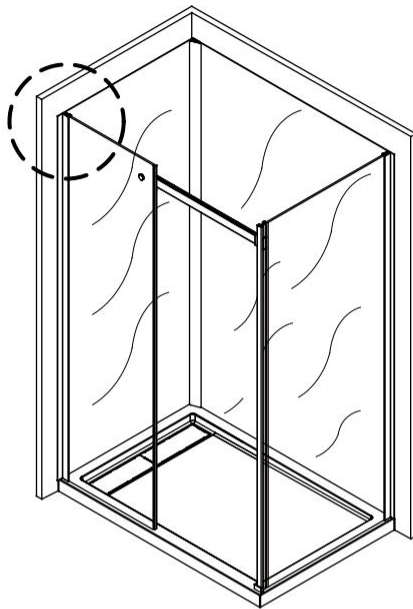
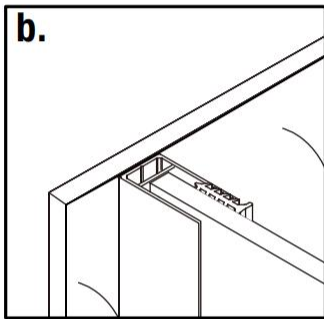
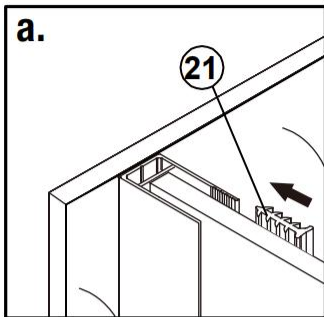

Shower door Installation • Installation des portes de la douche

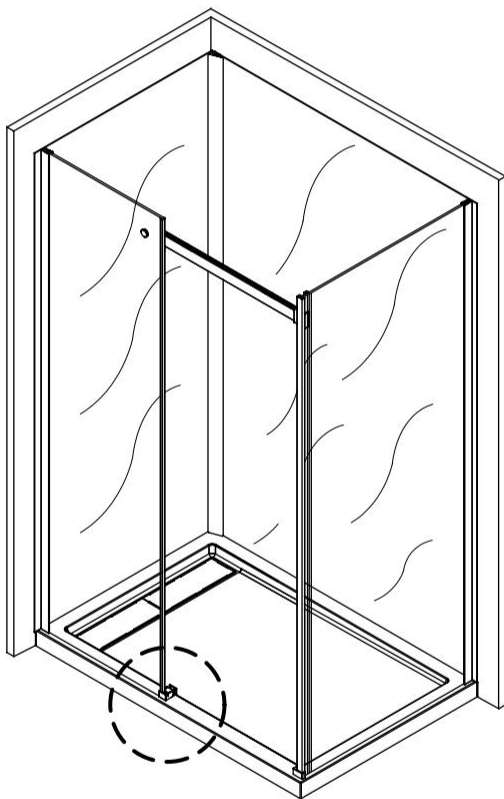
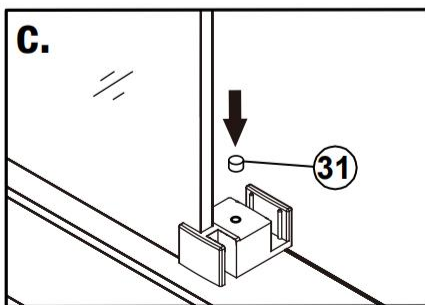
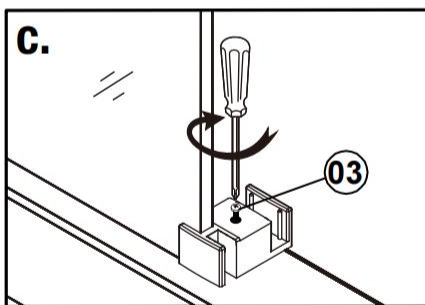
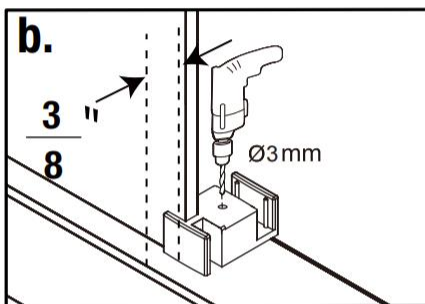
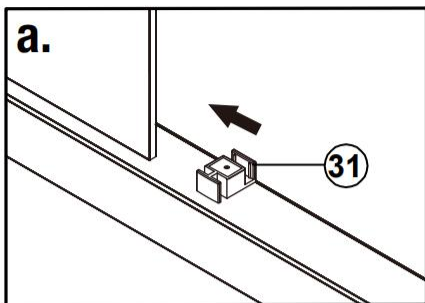

Shower door Installation • Installation des portes de la douche

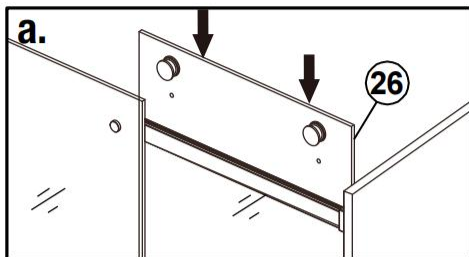

Hang the Glass Door to the Guide Rail and perform steps c and d to make sure they are leveled, then secure the Roller and close the lid.

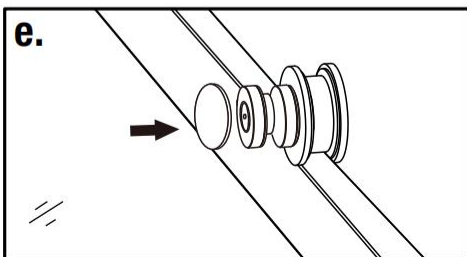
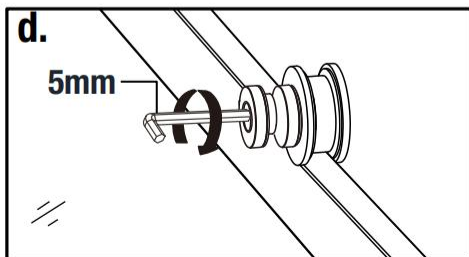
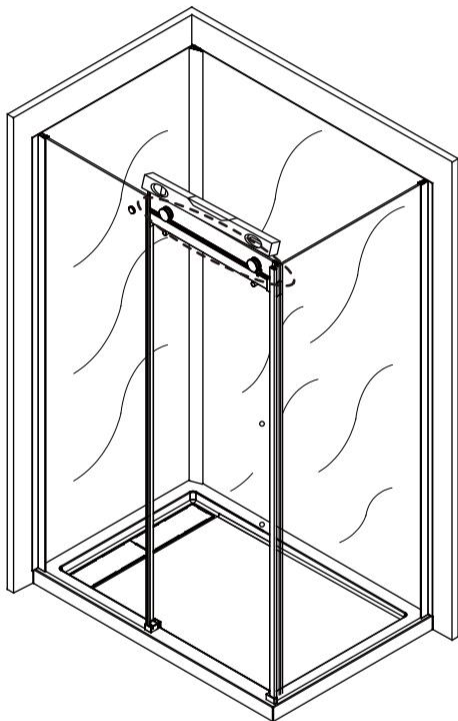
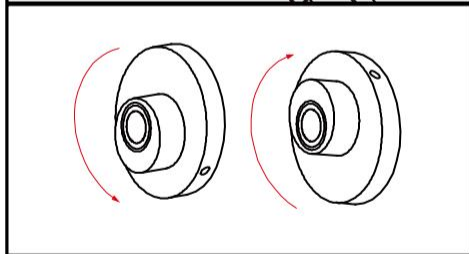
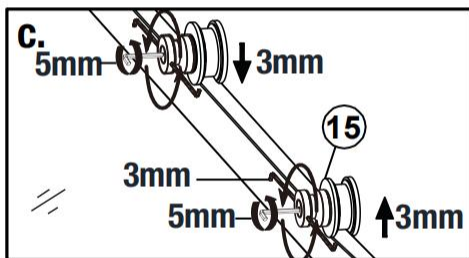
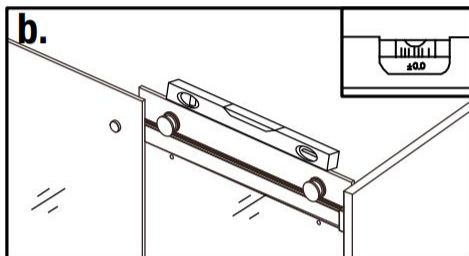

Shower door Installation • Installation des portes de la douche

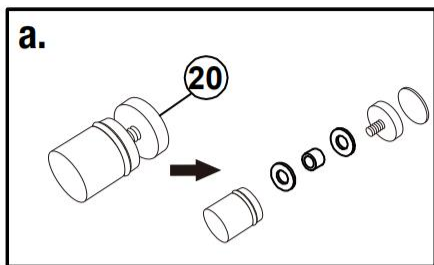

Press down the Door Guide so that it hooks into the slot of the Bottom Anti-Water Strip installed under the Glass Door.

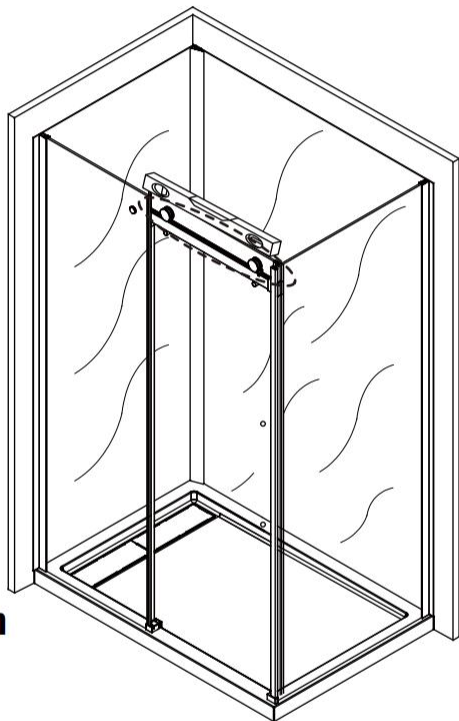
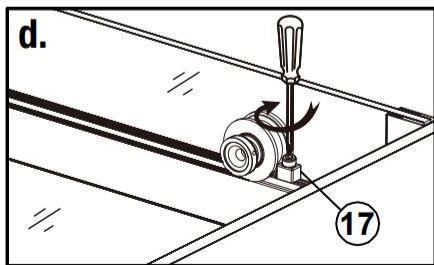
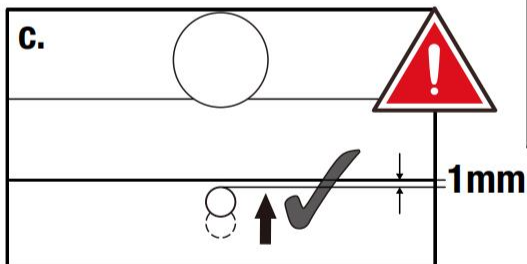
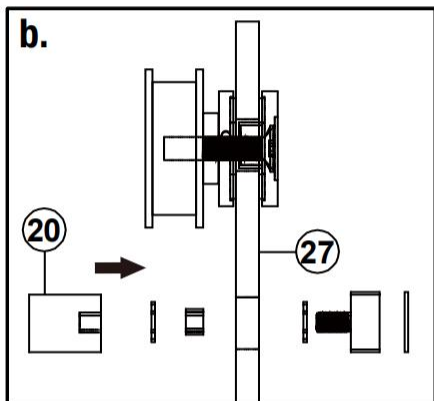

Shower door Installation • Installation des portes de la douche

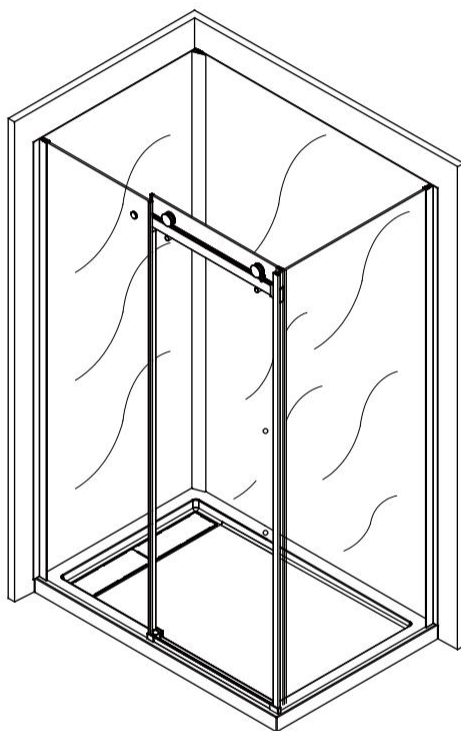
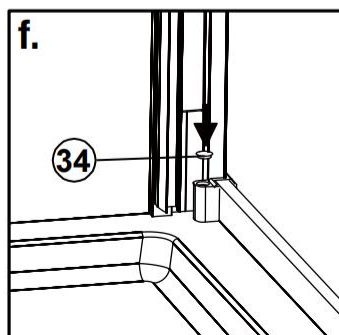
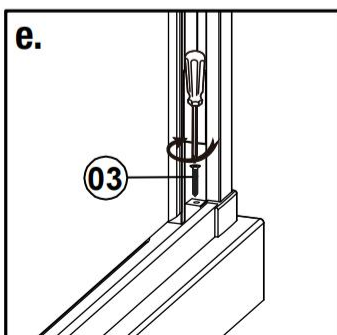
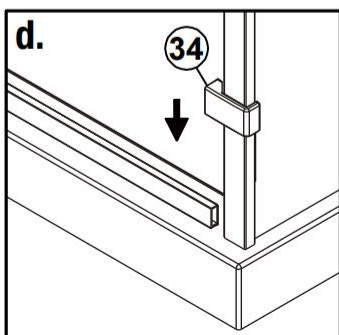
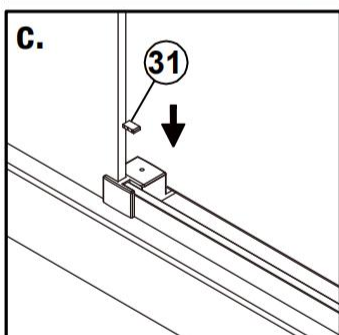
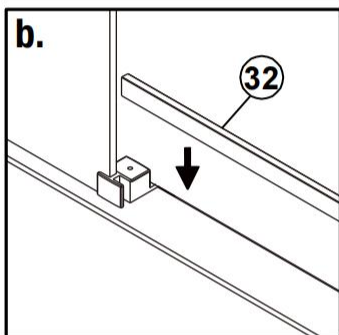
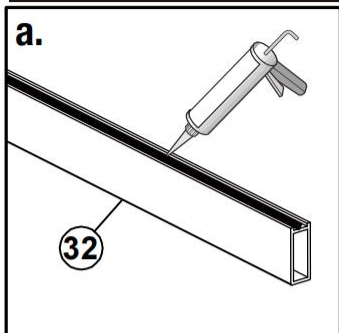

Shower door Installation • Installation des portes de la douche

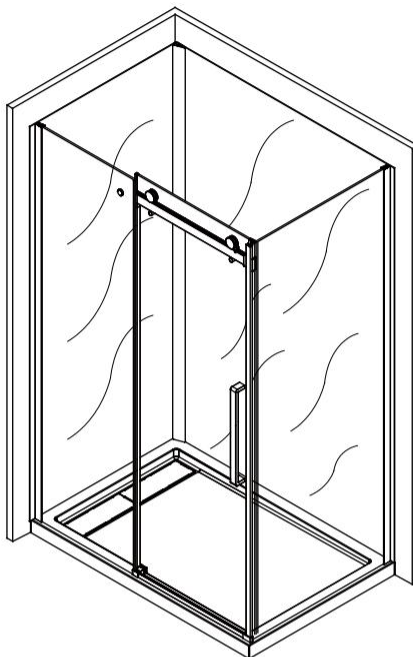
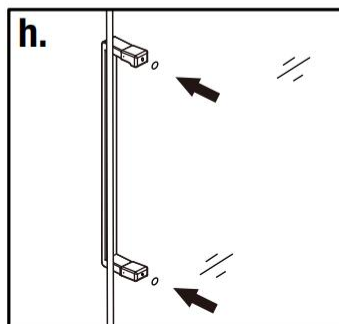
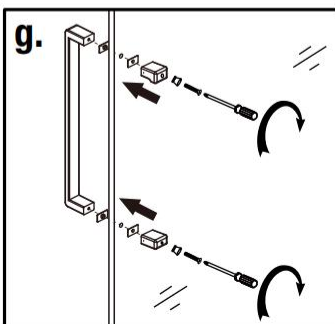
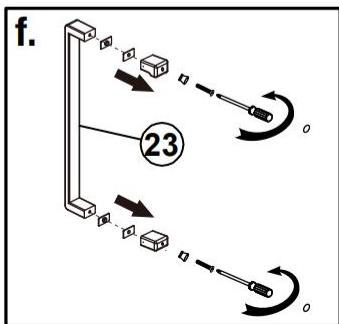
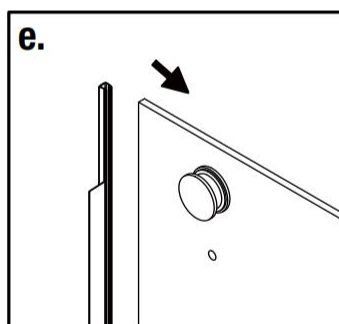
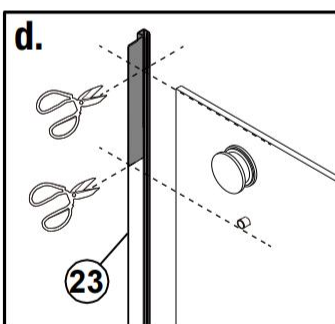
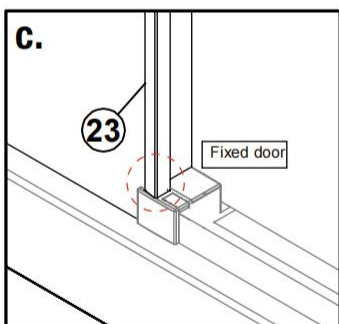
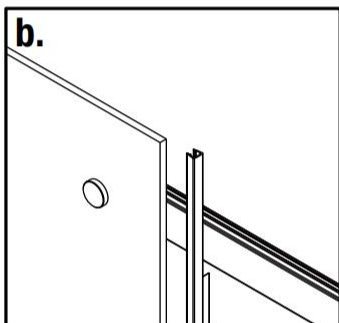
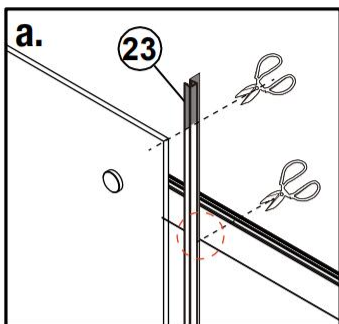

Shower door Installation • Installation des portes de la douche

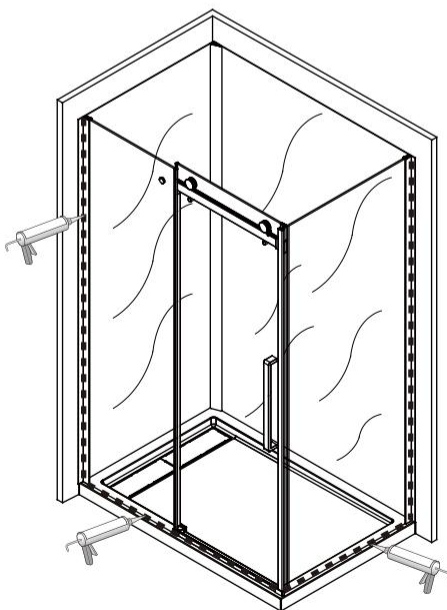
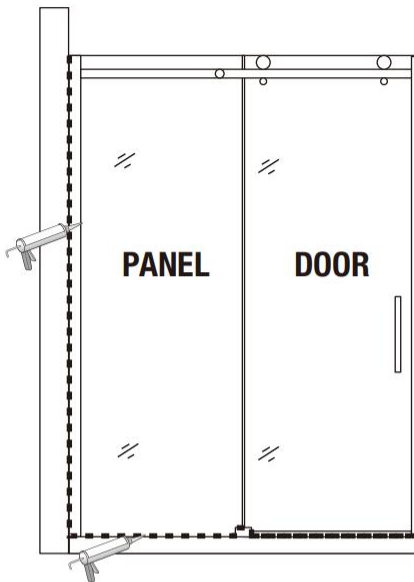
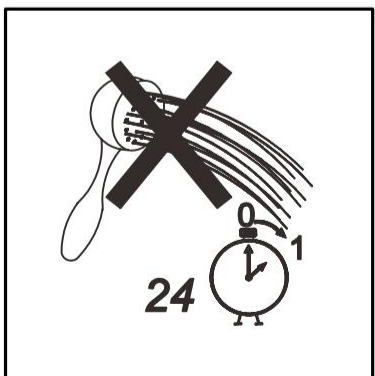
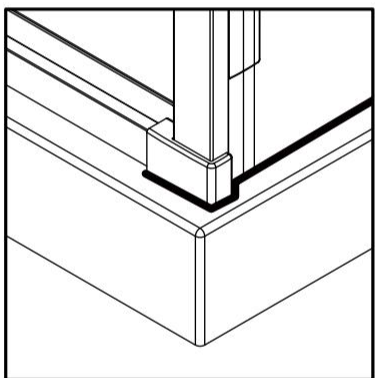
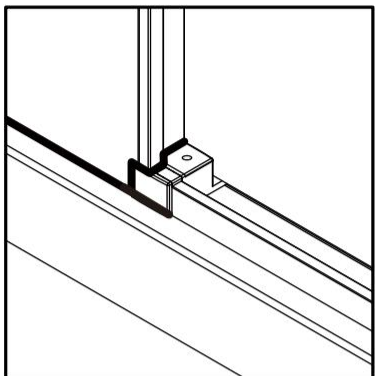

Decorative column installation • Installation de la barre décorative

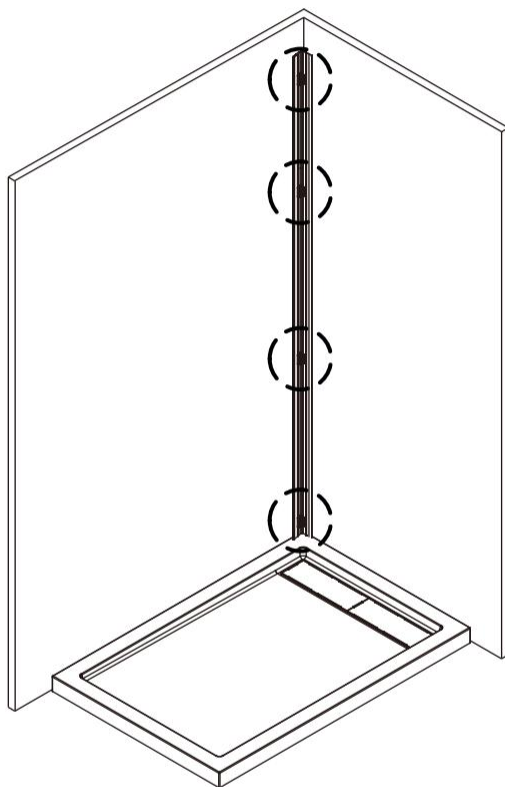
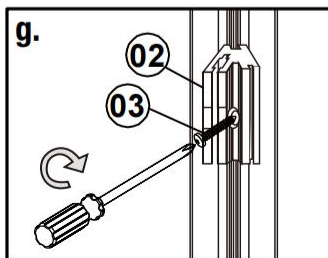
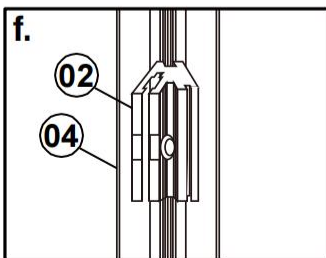
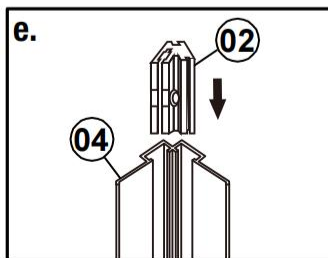
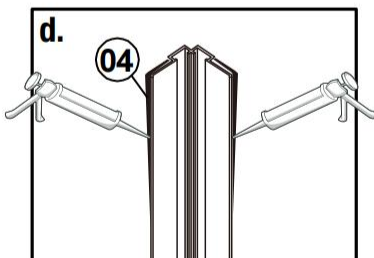
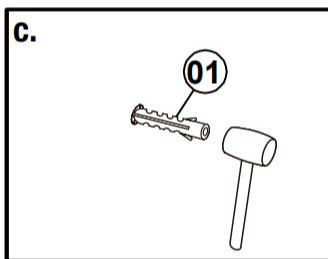
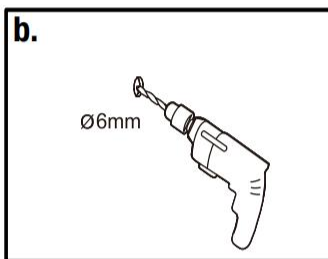
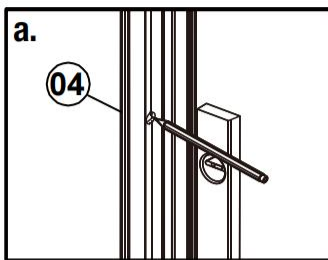

Decorative column installation • Installation de la barre décorative

Note:
Allow 24 hours for silicone to dry.

Remarque:
Laisser sécher le silicone pendant 24 heures.

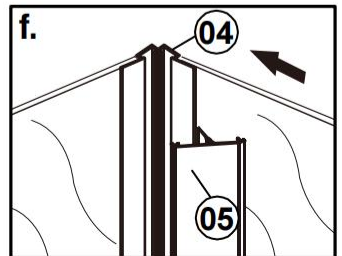
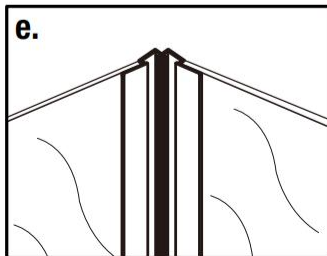
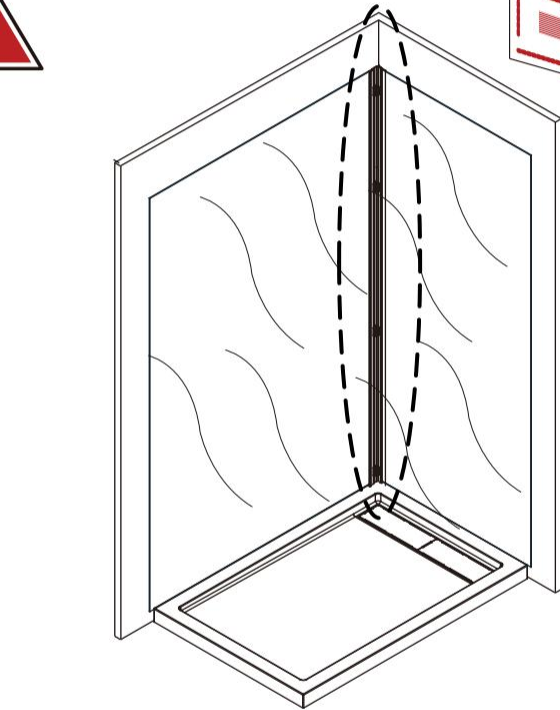
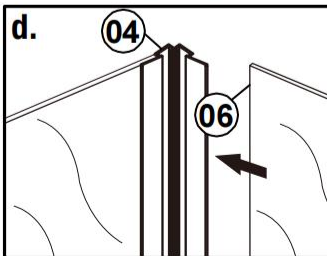
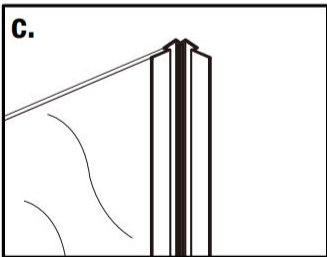
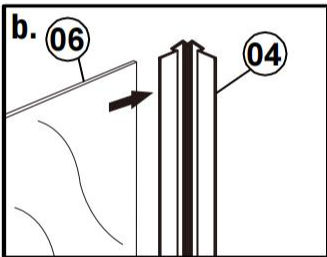
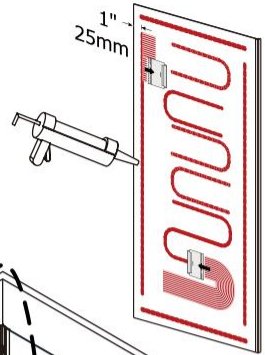

Decorative column installation • Installation de la barre décorative

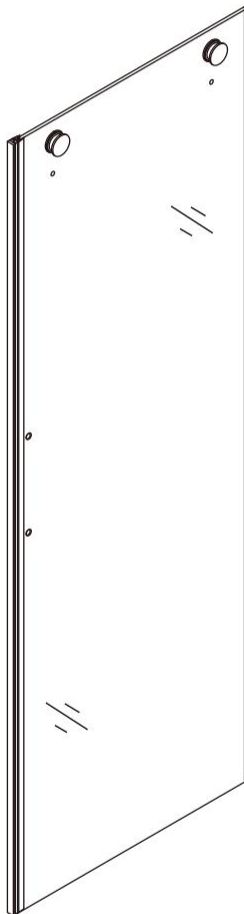
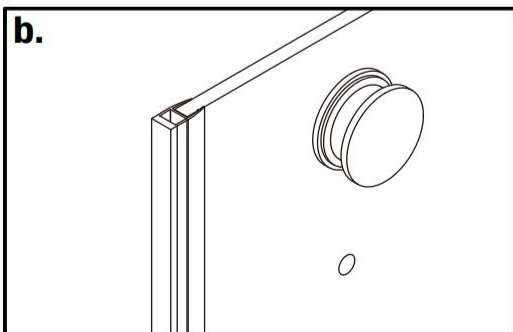
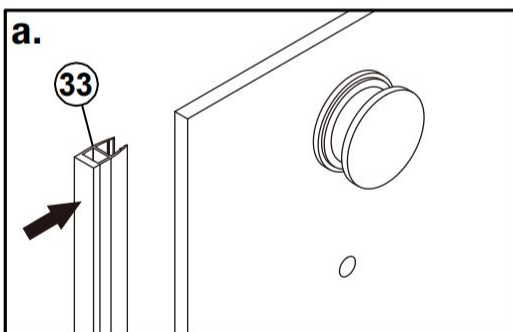
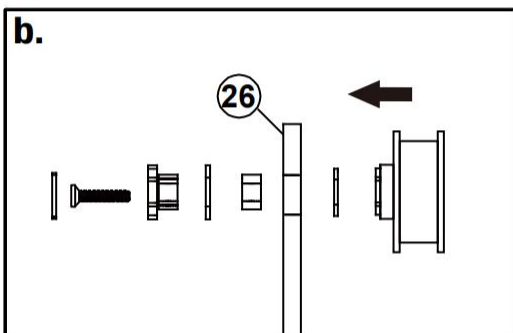
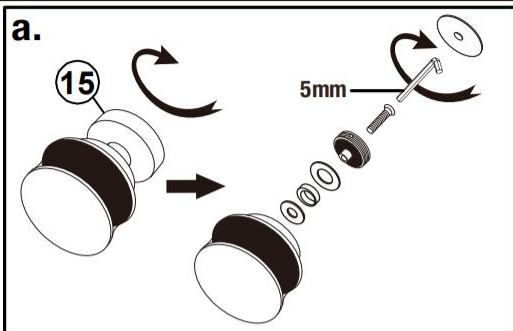

Decorative column installation • Installation de la barre décorative

Cover the shower base with a soft cloth/blanket. Carefully handle the glass door(15) to avoid scratching the shower base.

Attention:

DO NOT attach the handle to the Door Glass until instructed.

DO NOT attempt to lift the Glass Door with the handle as this may result in damage to the glass and/or serious personal injury. Use a professional grade glass suction cup and an assistant.

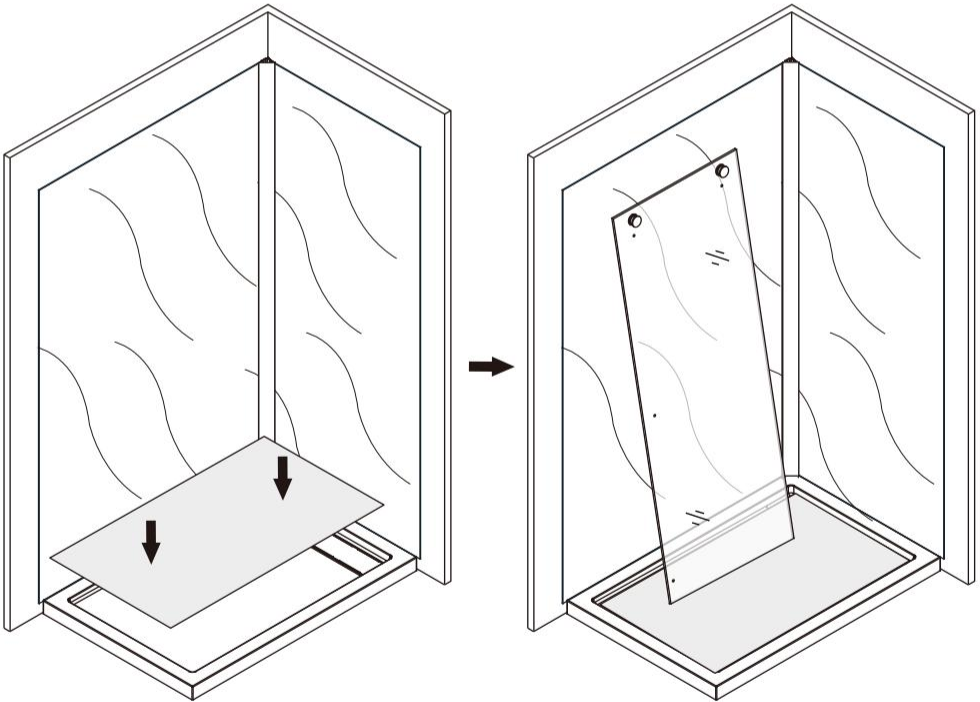

Decorative column installation • Installation de la barre décorative

Place the Wall Jamb on the **OTHER** side, mark down the predrilled position of the Wall Jamb. Drill the hole with 6mm drill bit, put silicone to the hole and then put anchor into the hole. Secure the Wall Jamb with M4*30 Screws.

Right-hand door installation shown. Continue on the right side for left-hand door installation.

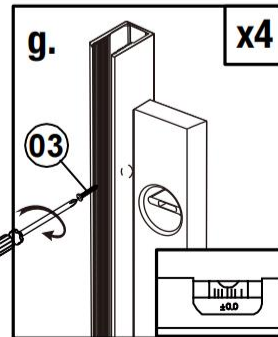
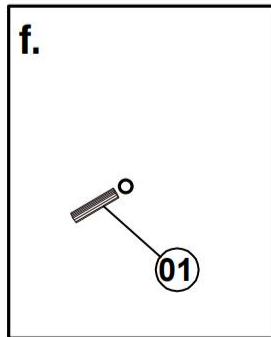
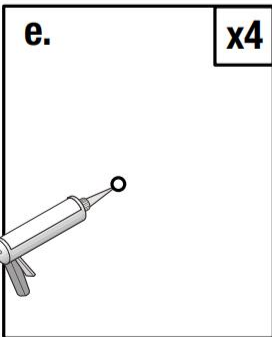
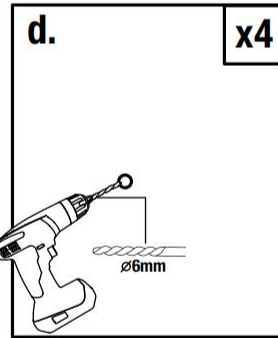
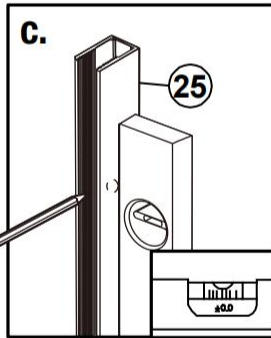
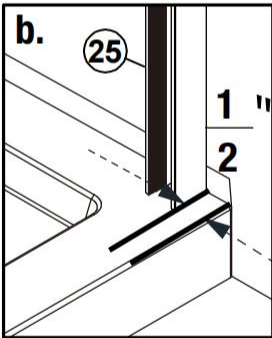
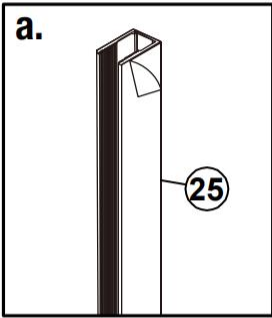
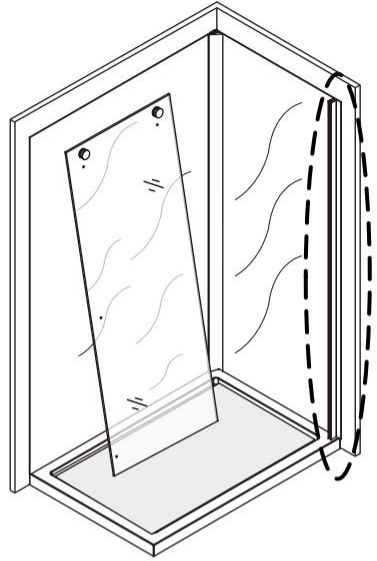

Decorative column installation • Installation de la barre décorative

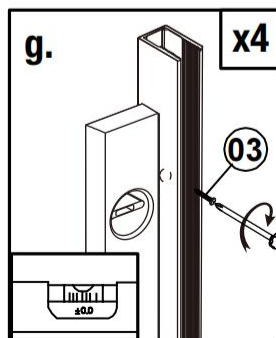
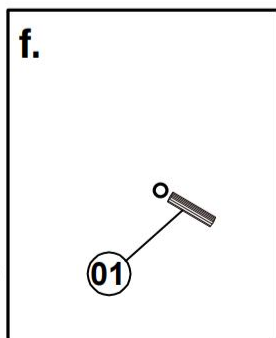
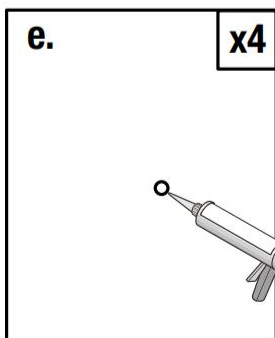
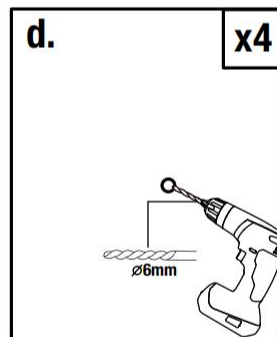
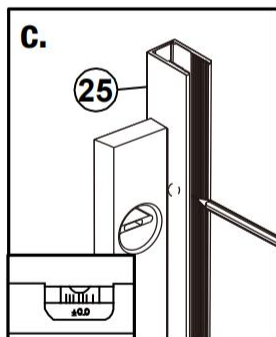
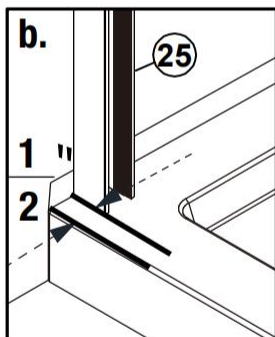
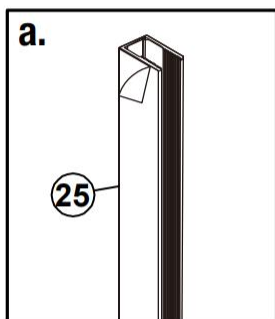
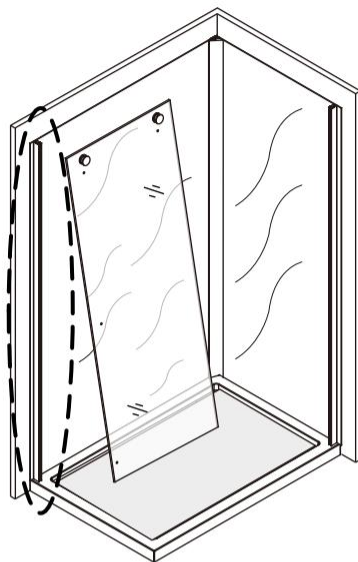

Glass shelf installation • Installation des étagères

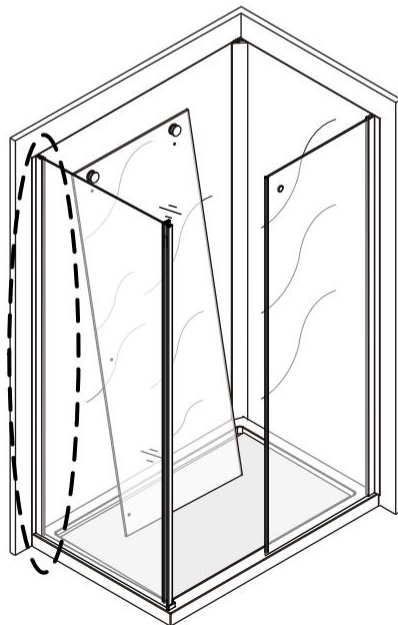
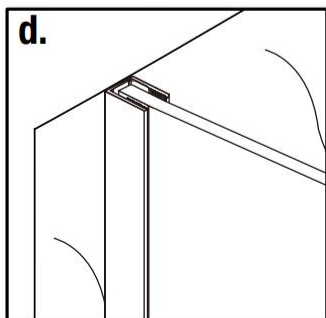
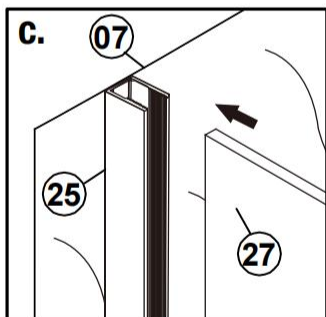
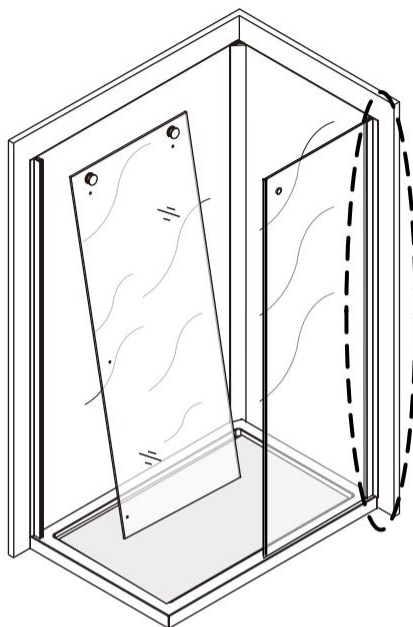
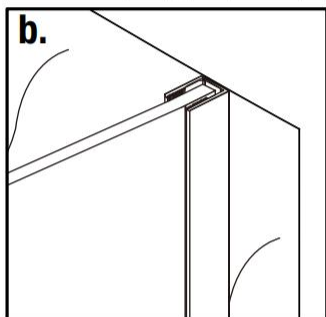
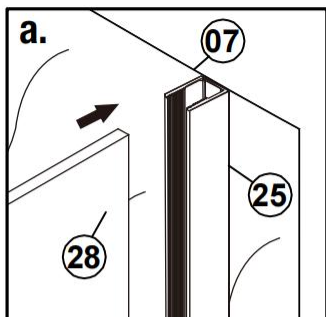

Shower door Installation • Installation des portes de la douche

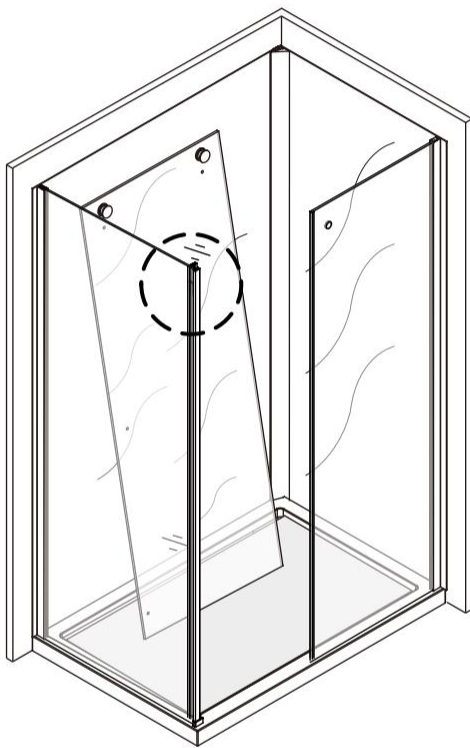
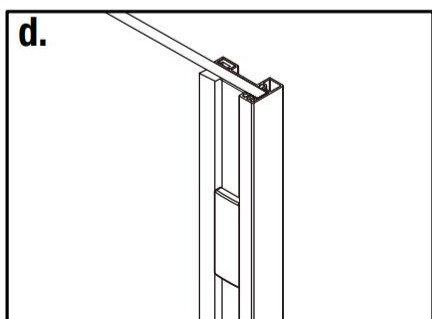
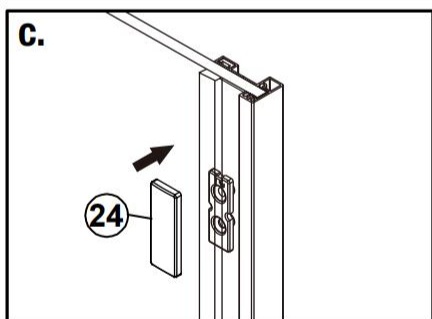
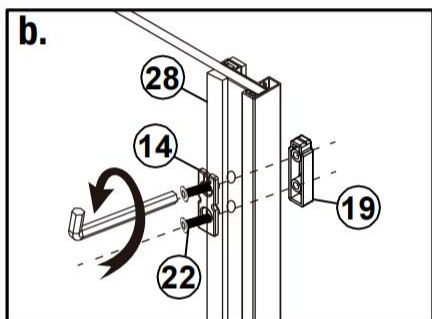
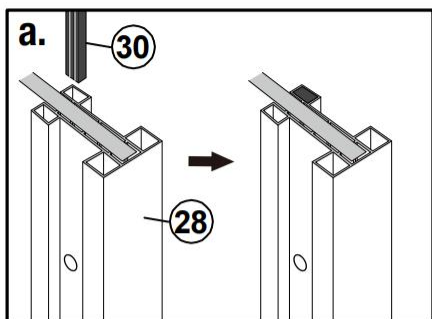

Shower door Installation • Installation des portes de la douche

Use the allen key (4mm) to loose the screw on the Guide Rail Brackets. Slide the Guide Rail Bracket onto the Guide Rail and use the allen key to temporarily tighten (slightly) the part to the Guide Rail.

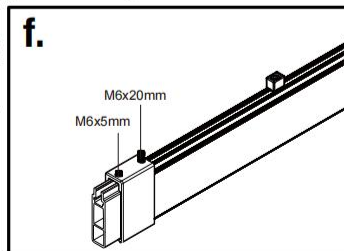
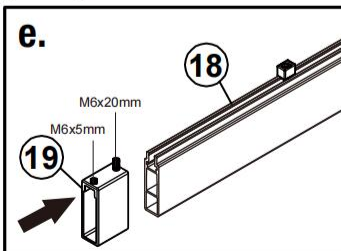
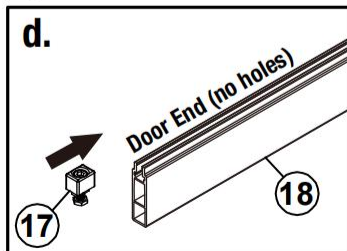
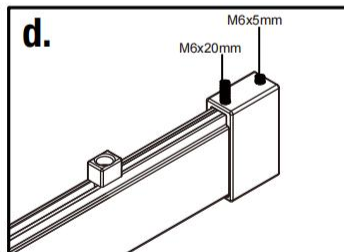
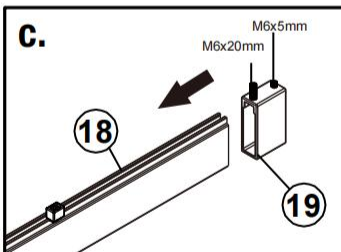
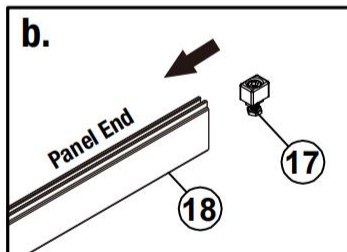
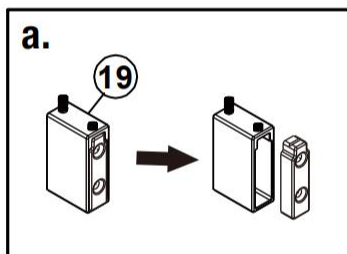
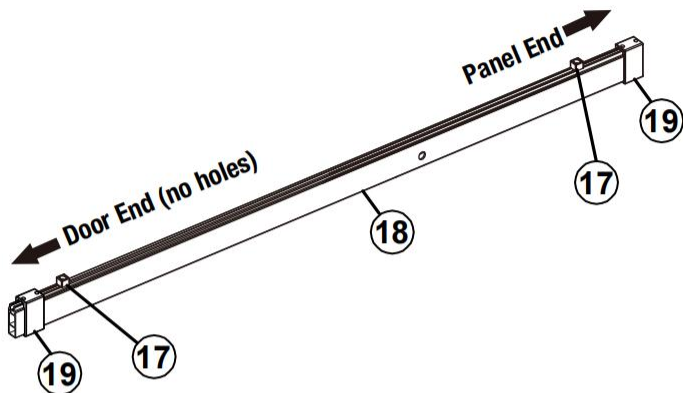

Shower door Installation • Installation des portes de la douche

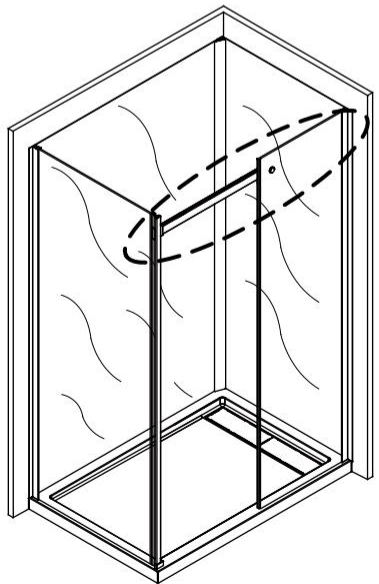
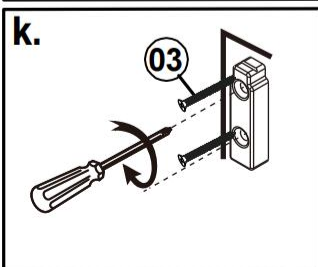
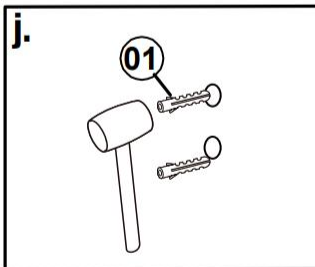
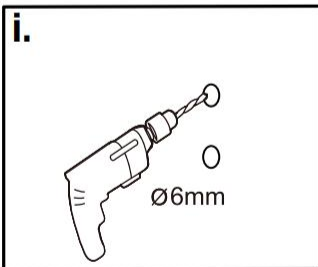
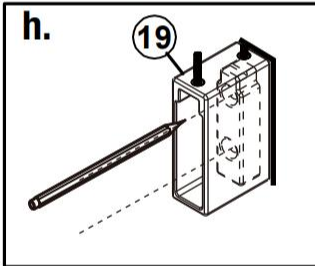
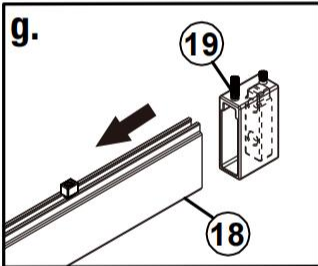
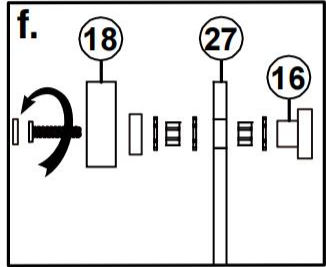
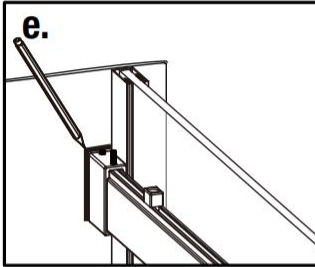
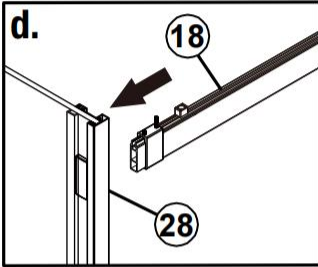
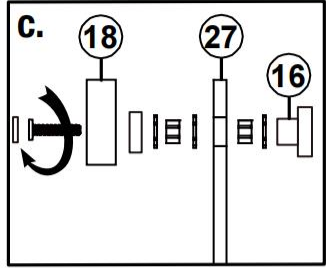
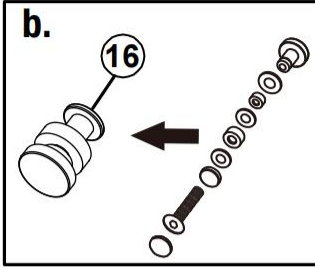
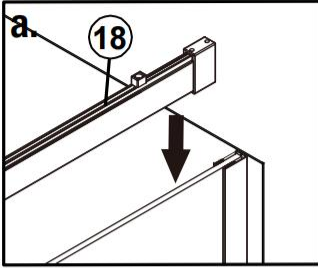

Shower door Installation • Installation des portes de la douche

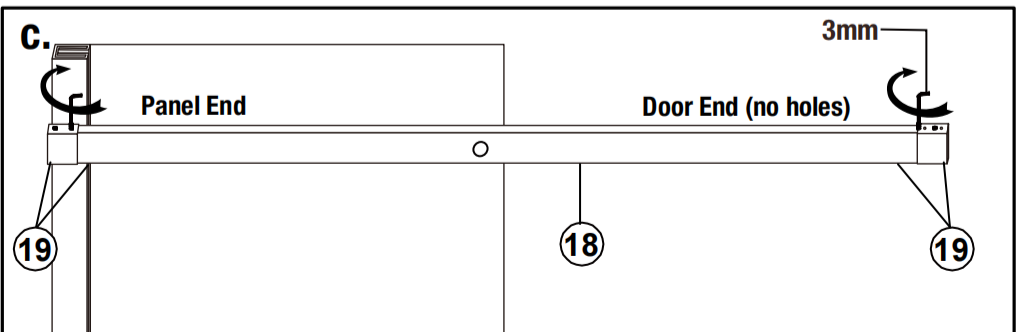
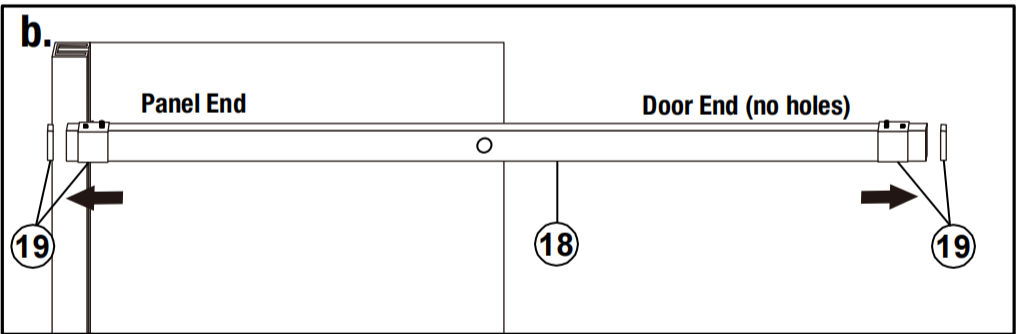
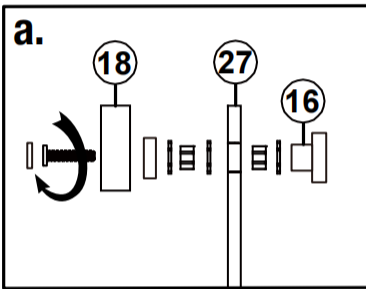
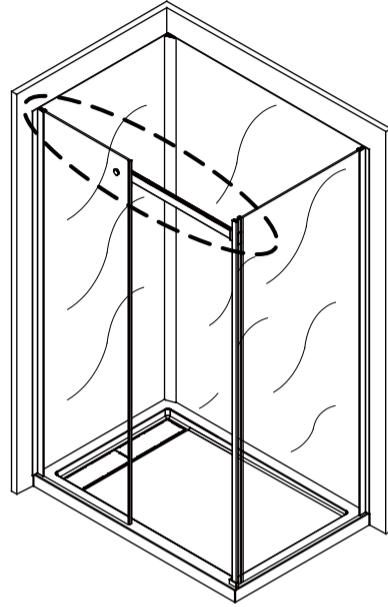

Shower door Installation • Installation des portes de la douche

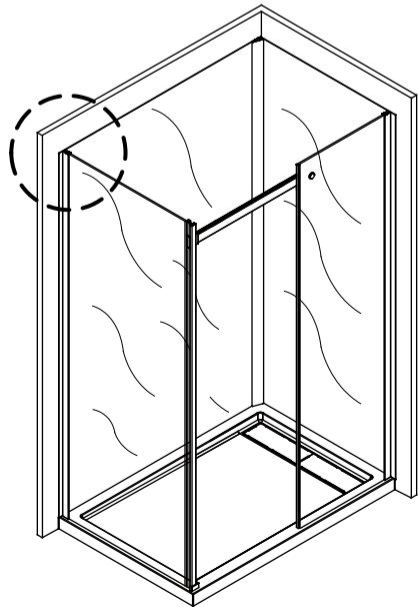
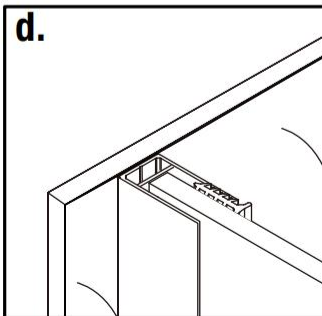
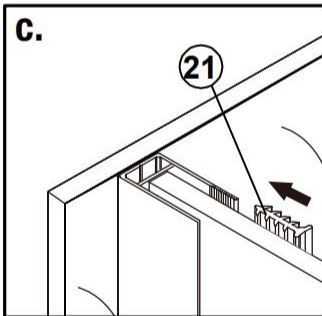
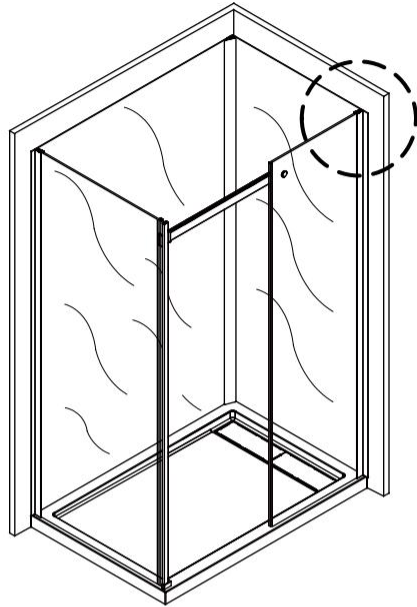
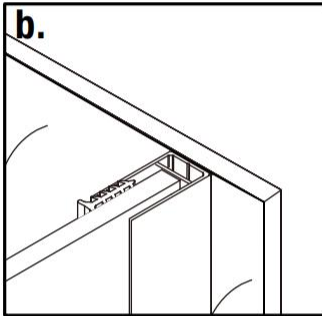
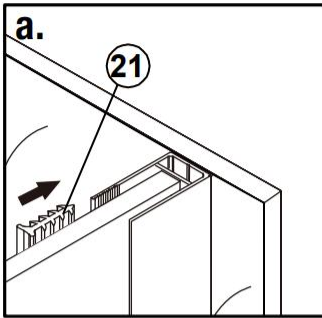

Shower door Installation • Installation des portes de la douche

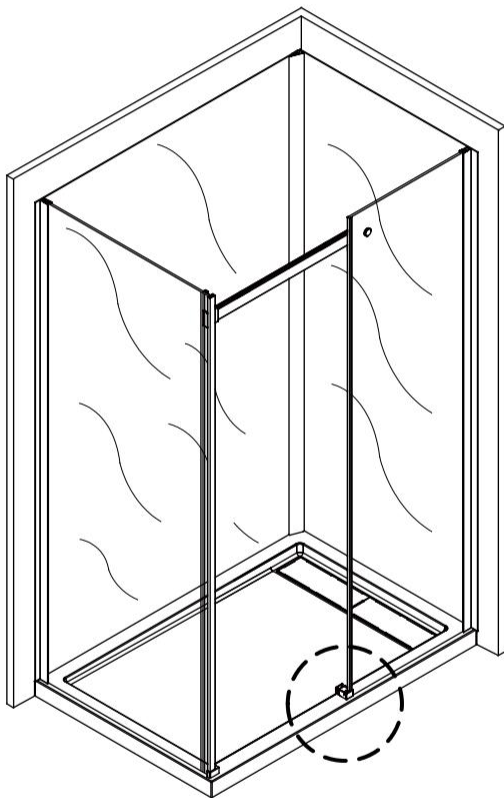
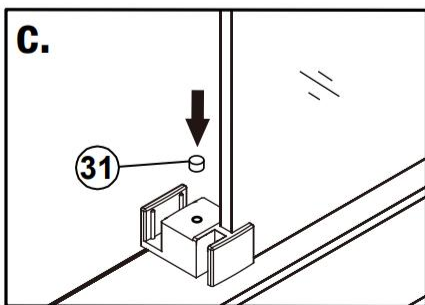
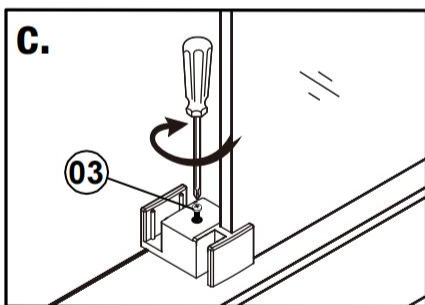
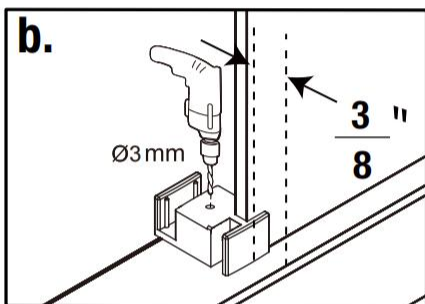
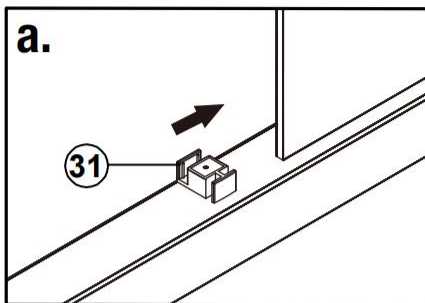

Shower door Installation • Installation des portes de la douche

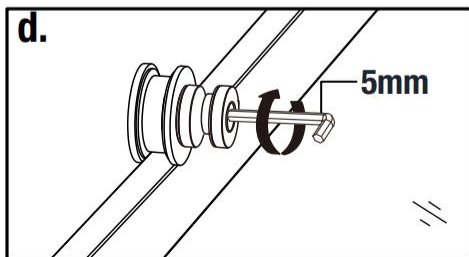
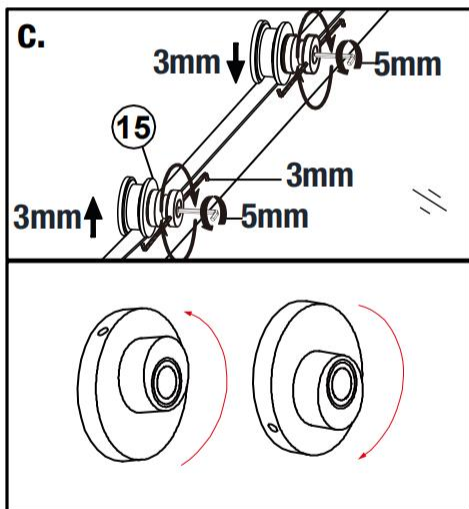
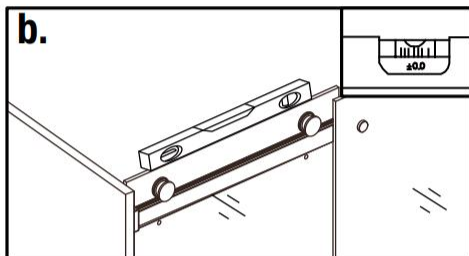
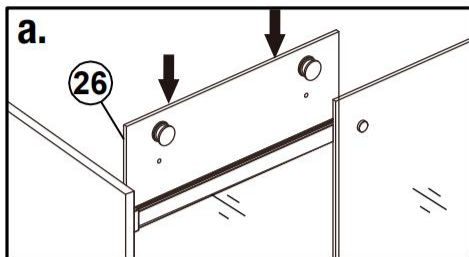

Hang the Glass Door to the Guide Rail and perform steps c and d to make sure they are leveled, then secure the Roller and close the lid.

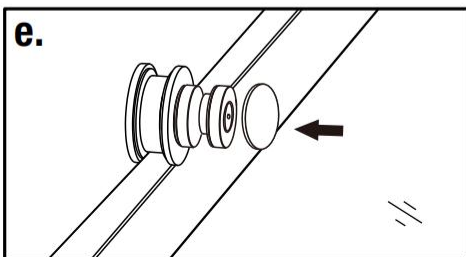
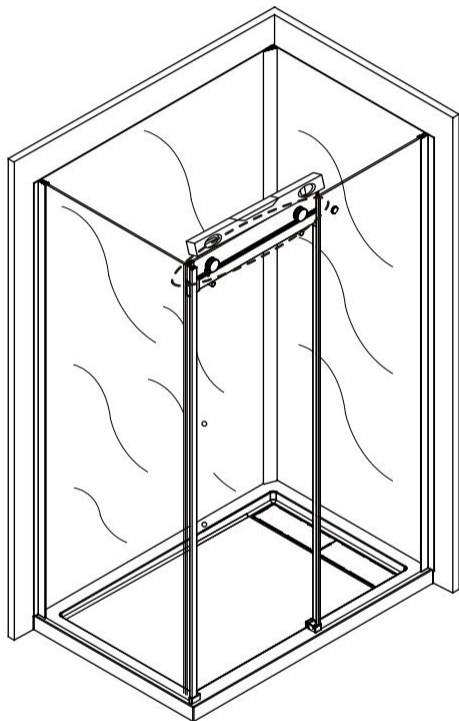

Shower door Installation • Installation des portes de la douche

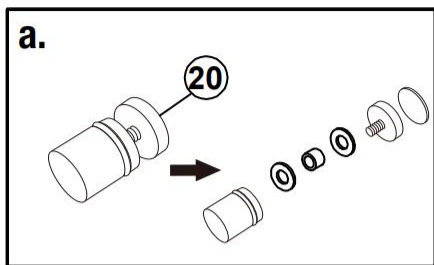

Press down the Door Guide so that it hooks into the slot of the Bottom Anti-Water Strip installed under the Glass Door.

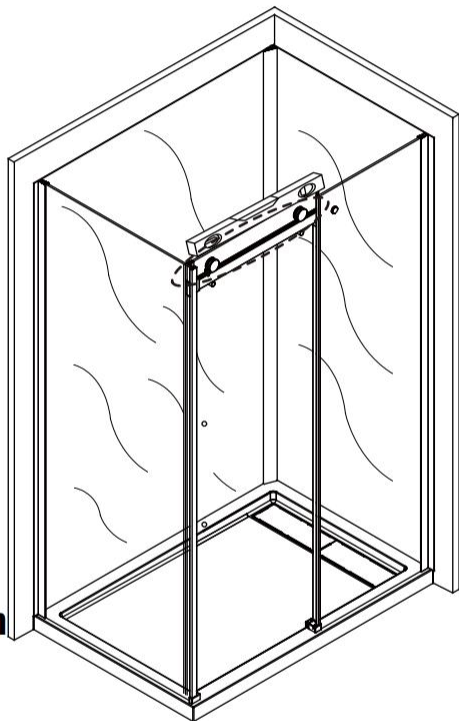
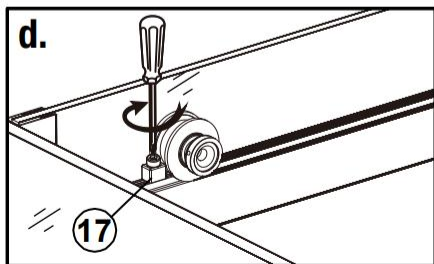
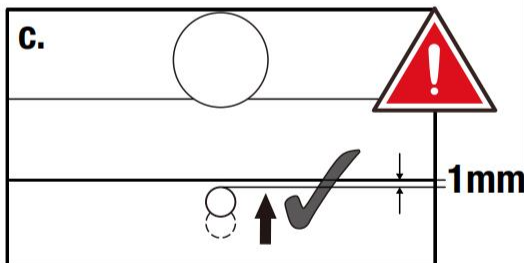
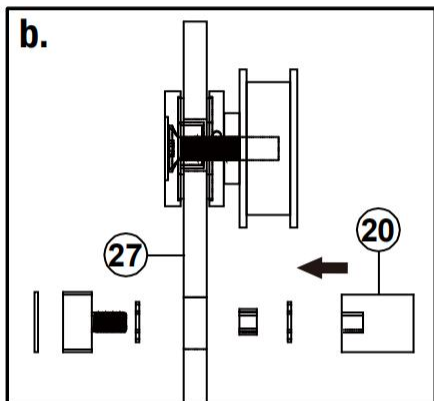

Shower door Installation • Installation des portes de la douche

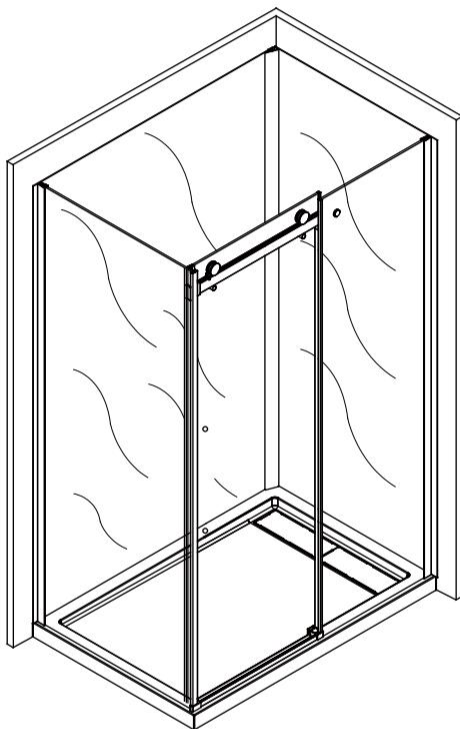
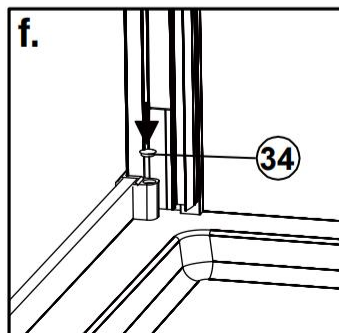
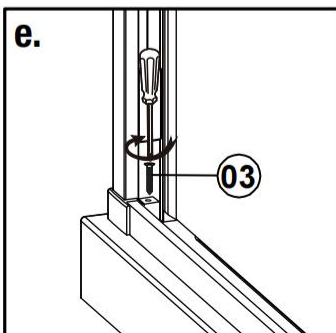
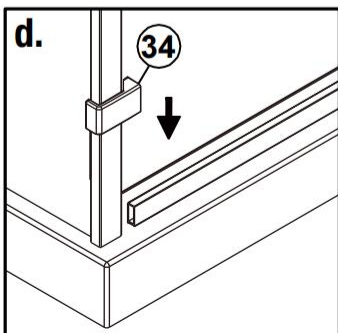
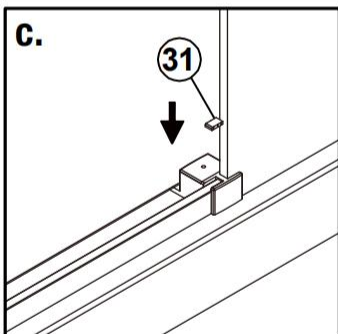
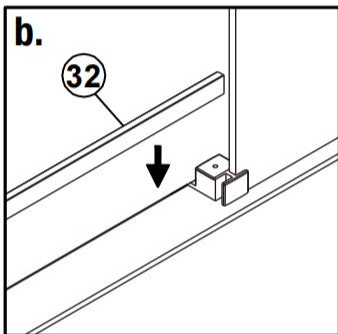
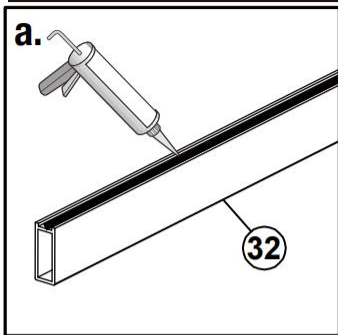

Shower door Installation • Installation des portes de la douche

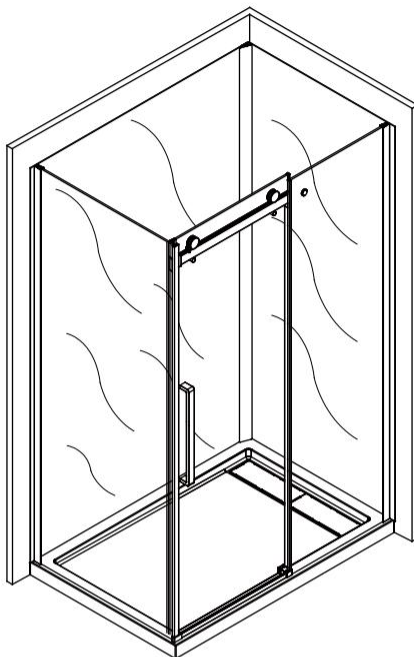
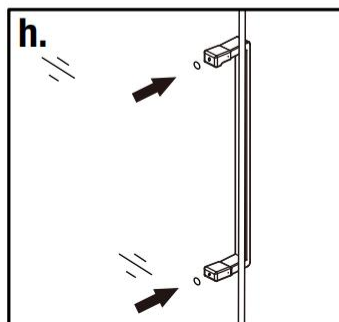
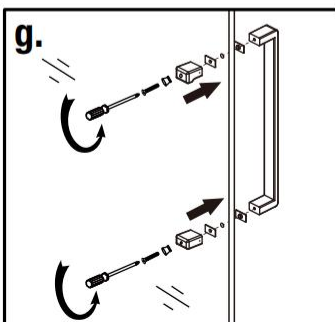
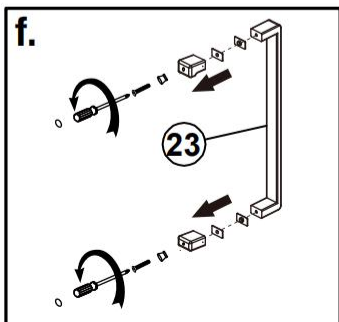
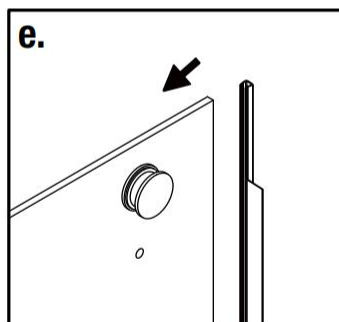
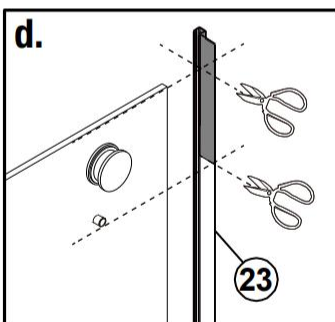
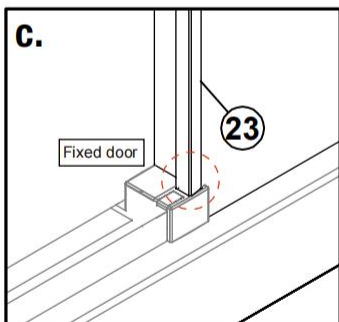
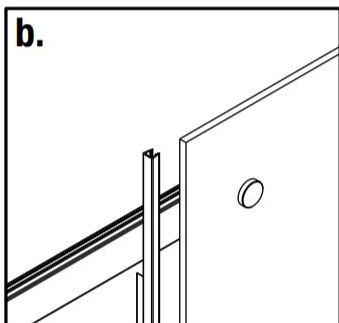
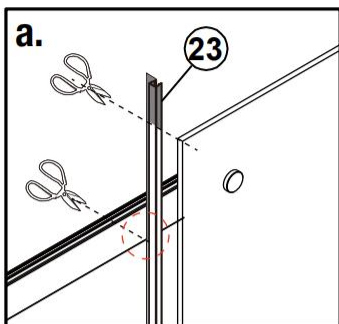

Shower door Installation • Installation des portes de la douche

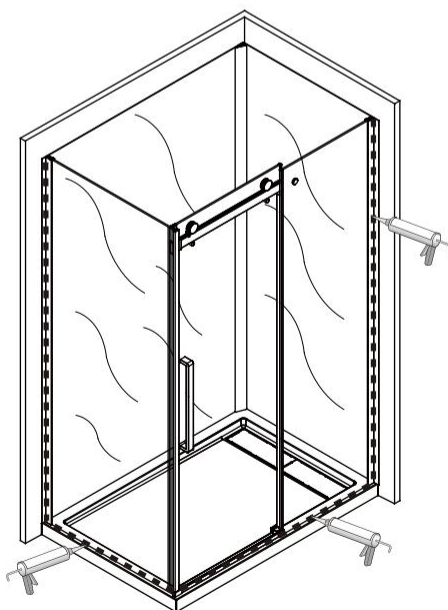
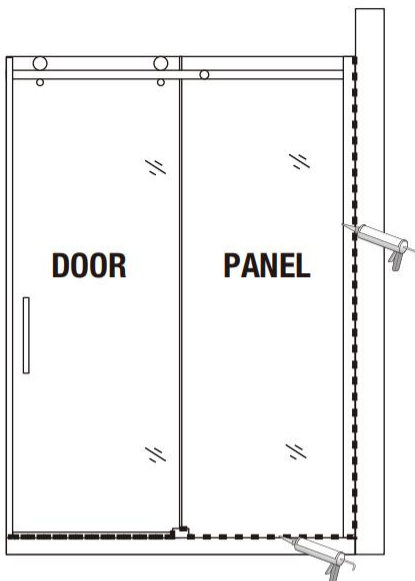
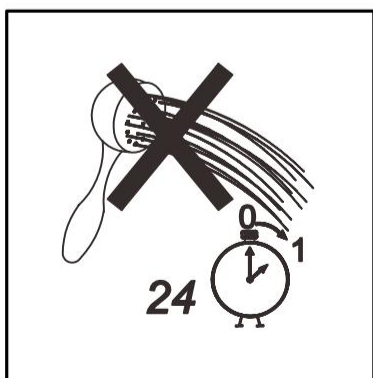
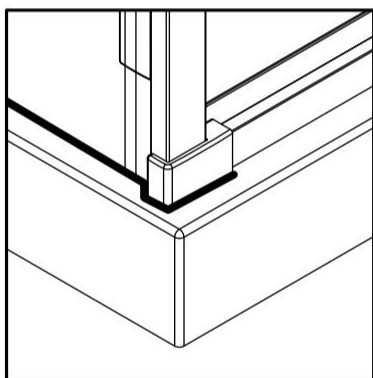
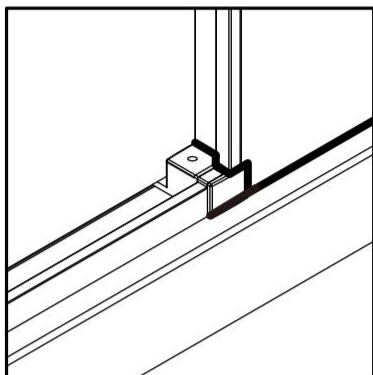

Shower leaks:

- Caulking must cover all seams without any gaps.
- Verify that the door gasket is straight.
- If there is some, remove all caulking found inside between the base and door of the shower.

Shower door does not close :

- Refer to door adjustment and shower squaring instructions.
- Verify that panels are level and seated properly on the base.
- Ensure that the door magnet properly overlaps latch post magnet. If overlap is correct, check that magnets are attracting each other. If not, remove the door magnet, reverse it, and reinsert.

La douche présente des fuites d'eau:

- Le calfeutrant doit recouvrir tous les joints sans laisser d'écart.
- Assurez-vous que le joint de la porte est droit.
- Il y a du calfeutrant à l'intérieur de la douche où la traverse inférieure fait contact avec la base (ne calfeutrez pas l'intérieur de la traverse).

La porte de la douche ne ferme pas:

- Consultez les instructions relatives à l'ajustement de la porte et à l'ajustement de la douche.
- Assurez-vous que les panneaux sont de niveau et qu'ils reposent bien sur la base.
- Assurez-vous que l'aimant de la porte recouvre bien l'aimant du verrou. Si c'est le cas, assurez-vous que les aimants s'attirent. S'ils se repoussent, retirez l'aimant de la porte et remplacez-le dans l'autre sens.

Maintenance • Entretien

Regular disinfection provides an effective defence against various types of bacteria that can develop in deposits that build up over time in all bathtubs and showers.

The clear panels, base and walls can be cleaned with a mild detergent solution, rinsed well and blotted dry with a chamois or soft cloth. Use a window glass cleaner for more stubborn stains but wipe off the surface immediately after applying the cleaner.

The base, walls and painted aluminum surfaces can be cleaned and their lustre restored with a mild automotive wax/polish (the wax will fill small scratches so surfaces will stay cleaner longer). Do not use rubbing compound; test the polish on a small area before using it on a particularly visible.

Do not use abrasive cleaners, scrapers, metal brushes or any object or product that could scratch or dull the surface.

Paint stains: Use turpentine or a paint thinner to remove paint stains.

Joint compound: Use a plastic or wood spatula covered with a damp cloth. Do not use a metal blade or brush.

If a rubber mat is placed in the shower, it must be removed immediately after each use. Ignoring this recommendation will cause damage not covered by the warranty.

Un nettoyage régulier constitue une excellente prévention contre les types de bactéries susceptibles de se développer au fil du temps dans les baignoires et les douches.

Les panneaux transparents, la base et les parois peuvent être nettoyés à l'aide d'une solution détergente douce. Rincez et séchez à l'aide d'un chamois ou d'un chiffon doux. Utilisez un nettoyant à vitres pour les taches plus tenaces, mais essuyez la surface immédiatement après l'avoir appliqué.

La base, les murs et les surfaces en aluminium peintes peuvent être nettoyés et peuvent retrouver leur lustre avec une cire ou un produit d'entretien (la cire pénètre dans les petites rayures, de sorte que la surface reste propre plus longtemps). N'utilisez pas de pâte à polir. Vérifiez le produit d'entretien sur une petite surface avant de l'appliquer sur une grande surface visible.

Ne jamais utiliser un nettoyant abrasif, un grattoir, une brosse métallique, ou tout autre objet ou produit pouvant égratigner ou ternir les surfaces.

Taches de peinture : utiliser de la térébenthine ou un diluant à peinture.

Composé à joint : utiliser une spatule de plastique ou de bois recouverte d'un linge humide ; éviter les lames de métal et les brosses métalliques.

Si un tapis de caoutchouc est utilisé, il est obligatoire de l'enlever immédiatement après chaque utilisation. L'utilisation non conforme d'un tel tapis causera des dommages exclus de la garantie.

Thank you for purchasing this Dolphin Plumbing Shower.

This product has been made to demanding, highquality standards and is guaranteed against manufacturing defects for service within the warranty period, please contact the store where the proof of purchase are required for any service request.

The product is guaranteed if used for normal trade purposes and remains valid for the original purchaser only.

Any guarantee will be deemed invalid if the product has been misused or neglected. Dolphin Plumbing cannot be held responsible for any labour costs, injuries or damage incurred during product installation, repair or replacement, including any consequential or indirect damages.

Due to continuous product improvement, we reserve the right to change the product specifications without prior notice.

Nous vous remercions d'avoir acheté une douche Dolphin Plumbing. Ce produit répond à des normes de haute qualité et est garanti contre tout défaut de fabrication pour une période de 1 ans à partir de la date d'achat.

Cette garantie n'affecte pas vos droits légaux.

Pour obtenir du service durant la période où vous avez acheté le produit. Le numéro de modèle du produit et une preuve d'achat sont nécessaires pour toute demande de service.

Ce produit est garanti si vendu par le biais d'un commerce à un consommateur pour son usage personnel et n'est valide si le produit est mal entretenu ou mal utilisé. Dolphin Plumbing ne peut être tenu responsable pour les frais de main d'oeuvre les blessures ou dommages pouvant être occasionnés au moment de l'installation, de la réparation ou du remplacement du produit, incluant les dommages indirects et immatériels.

Compte tenu de l'amélioration continue des produits, nous nous réservons le droit d'en modifier les spécifications sans préavis.

