

Installation Instructions for Laundry Tub Instructions d'installation de l'évier de lavage



Before starting your installation, please take a few minutes to READ THESE INSTRUCTIONS CAREFULLY. In addition, please check the product CAREFULLY for any visible damage.

Avant de commencer l'installation, veuillez prendre quelques minutes pour LIRE ATTENTIVEMENT CES CONSIGNES. De plus, veuillez examiner minutieusement le produit afin de déceler tout dommage apparent.

Recommended Tools & Materials



- Phillips Screwdriver
- Tournevis Phillips



- Adjustable Wrench
- Clé à Molette



- Regular Screwdriver
- Tournevis Régulier

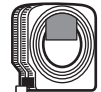

- Tape Measure
- Ruban à Mesurer



- Level
- Niveau



- Putty Knife
- Couteau à Mastic

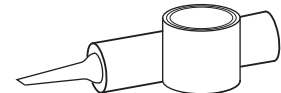

- Plumbers' Putty or Caulking
- Mastic de Plomberie ou Calfeutre

- 1** Fix the feet to the cabinet with screws.

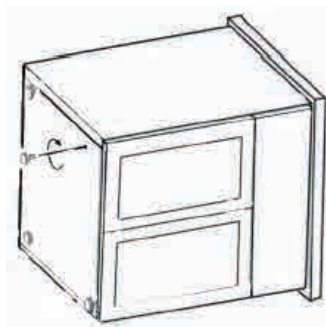

Fixer les pieds en dessous du meuble avec les quatre vis.

- 2** Fix the handle with screws.

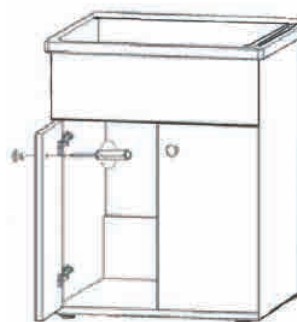

Fixer la poignée avec des vis.

- 3** To adjust the levelers under each foot.

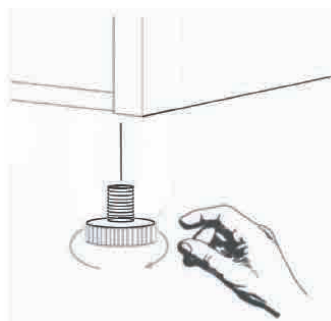

Mettre à niveau les pieds ajustables.

Installation Instructions for Laundry Tub Instructions d'installation de l'évier de lavage



Before starting your installation, please take a few minutes to READ THESE INSTRUCTIONS CAREFULLY. In addition, please check the product CAREFULLY for any visible damage.

Avant de commencer l'installation, veuillez prendre quelques minutes pour LIRE ATTENTIVEMENT CES CONSIGNES. De plus, veuillez examiner minutieusement le produit afin de détecter tout dommage apparent.

Installation of the plumbing parts

Installation des pièces de plomberie

Strainer Parts

Pièces du filtre



- Strainer basket
- Strainer body
- Rubber gasket
- Under gasket
- Lock nut
- Panier-filtre
- Corps du filtre
- Joint en caoutchouc
- Sous-joint
- Contre-écrou

● P-trap parts

● Pièces du siphon-P

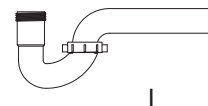

- Gasket
- Strainer tail
- Gasket
- P-trap
- Joint d'étanchéité
- Queue du filtre
- Joint d'étanchéité
- Siphon-P

- 4** Turn the sink upside down on a non-abrasive surface. Place gasket (F) on the strainer. Fix the top of the strainer tailpiece (G) to the gasket (F).

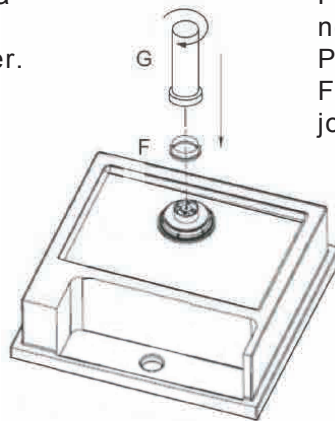

Placer la cuve à l'envers sur une surface non abrasive. Placer le joint d'étanchéité (F) sur le filtre. Fixer le haut de la queue du filtre (G) au joint d'étanchéité (F).

Installation Instructions for Laundry Tub Instructions d'installation de l'évier de lavage



Before starting your installation, please take a few minutes to READ THESE INSTRUCTIONS CAREFULLY. In addition, please check the product CAREFULLY for any visible damage.

Avant de commencer l'installation, veuillez prendre quelques minutes pour LIRE ATTENTIVEMENT CES CONSIGNES. De plus, veuillez examiner minutieusement le produit afin de détecter tout dommage apparent.

- 5** Connect the P-trap to the strainer tailpiece by placing the gasket (H) first. You can cut the tailpiece and adjust the P-trap according to the position of the inlet of the waste.

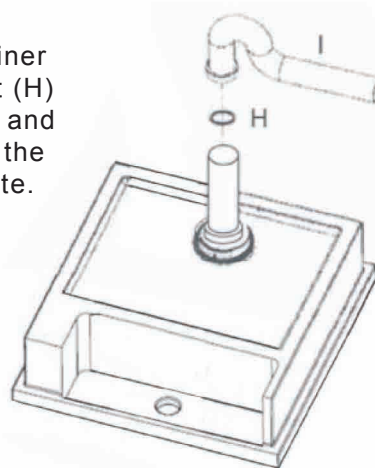

Connecter le siphon-P à la queue du filtre en prenant soin de placer le joint d'étanchéité (H) entre les deux. Vous pouvez couper la queue et ajuster le siphon en P selon la position d'entrée des eaux usées.

- 6** The assembly of plumbing parts is complete.

L'assemblage des pièces de plomberie est complété.

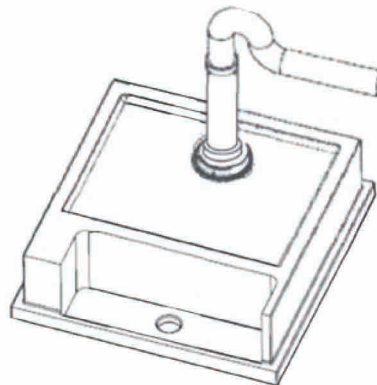

- 7** Install faucet according to faucet's manual.

Installer le robinet en suivant les indications du manuel d'installation du robinet