

Installation Instructions Instructions d'installation



Before starting your installation, please take a few minutes to READ THESE INSTRUCTIONS CAREFULLY. In addition, please check the product CAREFULLY for any visible damage.

Avant de commencer l'installation, veuillez prendre quelques minutes pour LIRE ATTENTIVEMENT CES CONSIGNES. De plus, veuillez examiner minutieusement le produit afin de détecter tout dommage apparent.

TOOLS REQUIRED / OUTILS NÉCESSAIRES



NOTE: Tools shown are not included.
REMARQUE: Outils et matériaux recommandés (non inclus).



Phillips screwdriver
Tournevis cruciforme



Regular screwdriver
Tournevis plat



Level
Niveau



Hammer
Marteau



Tape measure
Ruban à mesurer

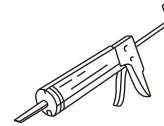

Latex sealant
Scellant au latex

1

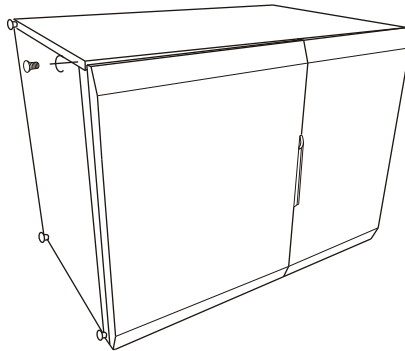

To fix the feet on cabinet
with screws.

Fixer les pattes sous l'armoire
avec les vis.

2

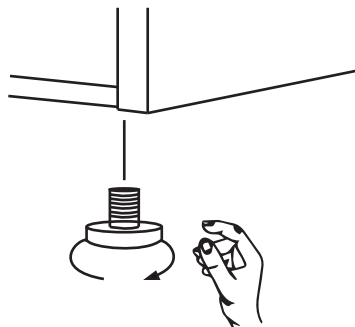

To adjust the levelers under
each foot.

Mettre à niveau les pieds
ajustables.

Installation Instructions Instructions d'installation



Before starting your installation, please take a few minutes to READ THESE INSTRUCTIONS CAREFULLY. In addition, please check the product CAREFULLY for any visible damage.

Avant de commencer l'installation, veuillez prendre quelques minutes pour LIRE ATTENTIVEMENT CES CONSIGNES. De plus, veuillez examiner minutieusement le produit afin de détecter tout dommage apparent.

Next step - Assembling plumbing parts.
You will need the following pieces (included)

Prochaine étape: assemblage des pièces de plomberie.
Vous aurez besoin des pièces suivantes (incluses):

Strainer Parts

Pièces du filtre



A
Strainer basket
Panier-filtre



B
Strainer body
Corps du filtre



C
Rubber gasket
Rondelle en caoutchouc



D
• Under gasket
• Sous-rondelle



E
• Lock nut
• Contre-écrou

P-trap parts / Pièces du siphon en P



F
Gasket
Joint d'étanchéité



G
Strainer tailpiece
Queue du filtre



H
Gasket
Joint d'étanchéité



I
P-trap
Siphon en P

3

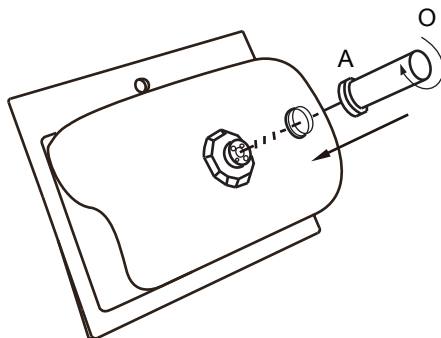

Turn the sink upside down on a non-abrasive surface.
Place gasket (F) on the strainer.
Fix the top of the strainer tailpiece (G)
to the gasket (F).

Placer la cuve à l'envers sur une surface non abrasive.
Placer le joint d'étanchéité (F) sur le filtre.
Fixer le haut de la queue du filtre (G)
au joint d'étanchéité (F).

Installation Instructions Instructions d'installation



Before starting your installation, please take a few minutes to READ THESE INSTRUCTIONS CAREFULLY. In addition, please check the product CAREFULLY for any visible damage.

Avant de commencer l'installation, veuillez prendre quelques minutes pour LIRE ATTENTIVEMENT CES CONSIGNES. De plus, veuillez examiner minutieusement le produit afin de détecter tout dommage apparent.

4

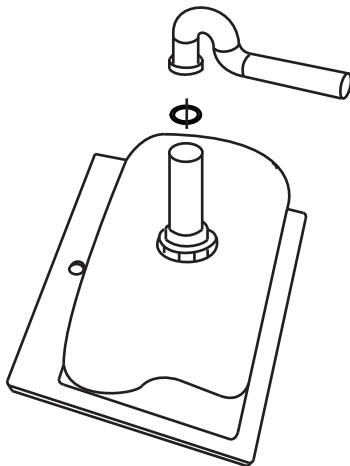

Connect the P-trap to the strainer tailpiece by placing the gasket (H) first. You can cut the tailpiece and adjust the P-trap according to the position of the inlet of the waste.

Connecter le siphon-P à la queue du filtre en prenant soin de placer le joint d'étanchéité (H) entre les deux. Vous pouvez couper la queue et ajuster le siphon en P selon la position d'entrée des eaux usées.

5

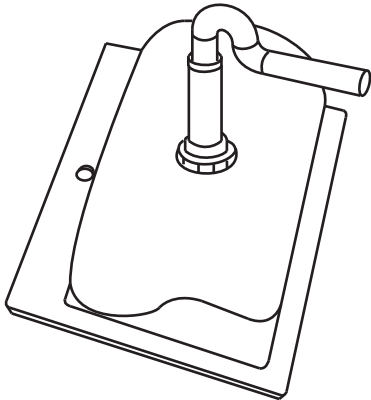

The assembly of plumbing parts is complete.

L'assemblage des pièces de plomberie est complété.

6

Turn sink right side up and place carefully onto assembled vanity. Install faucet according to faucet's manual.

Retournez la cuve à l'endroit et placez-la avec précaution sur le meuble. Installer le robinet en suivant les indications du manuel d'installation du robinet.